



Formerly JDSU

Introduction to DOCSIS 3.1

Larry Jump

SCTE

February 2017

814 692 4294

larry.jump@viavisolutions.com

<http://www.catvsupport.com/index3.html>

TAC 866 228-3762 Option 3,1, 2

Thought you knew everything there is to know about DOCSIS?



**Buckle Up Kids!
Time to start all over again!**

Agenda

DOCSIS History
Goals and Benefits of D 3.1
Frequency Splits
OFDM / OFDMA
LDPC
Physical Layer Channels
Pilots
Modulation Profiles
Upstream
Testing

DOCSIS History

Summary of DOCSIS Releases:

DOCSIS 1.0 March 1997

- Beginning of data over cable system interface specification (DOCSIS)
- Defined support for high speed data over HFC

DOCSIS 1.1 April 1999

- Adds state of the art QoS techniques for priority services (e.g. VoIP)

DOCSIS 2.0 December 2001

- Increased upstream modulation format for more b/s/Hz
- Adds new physical layer (PHY) for the upstream Synchronous Code Division Multiple Access (SCDMA)
- Defined a state of the art advanced media access layer (MAC) (even to this day)
- Enabled two (2) dimensional upstream bandwidth allocation and/or simultaneous transmission within the same channel for quality of service (QoS) and quality of experience (QoE)

DOCSIS History

- **DOCSIS 3.0 August 2006**
 - Added IPV6 and multicast QoS
 - Channel Bonding
 - Kept old modulation formats and FEC

DOCSIS 3.1

DOCSIS 3.1 October 2013

- Enables backward compatibility (as opposed to coexistence)
 - Avoids spectrum tax (allocating separate spectrum for legacy and new)
 - Leverage DOCSIS MAC across legacy single carrier (SC) PHY & new orthogonal frequency division multiplexing (OFDM) PHY
 - Enable single carrier QAM (SC-QAM) and OFDM to share a bonding group
- Data rate capacity increases
 - Enables 10+ Gbps downstream capacity
 - Enables 1+ Gbps upstream capacity
 - The maximum is unbounded (10 – 20 Gb/s or even higher)

DOCSIS 3.1 specifications cont.

- Modernize the PHY Layer (to increase bits per Hz)
 - Support legacy DOCSIS PHYs plus
 - Downstream & upstream modulation formats (16384 QAM / 4096 QAM)
 - Adds downstream orthogonal frequency-division multiplexing (OFDM)
 - Adds upstream orthogonal frequency-division multiple access (OFDMA)
 - Adds error correction technology
 - Outer FEC: Bose-Chaudhuri-Hocquenghem (BCH) codes
 - Inner FEC: Low-Density Parity-Check (LDPC) codes
 - The changing of the FEC in DOCSIS 3.1 from DOCSIS may result in:
 - Gain could be up to two modulation orders in the same SNR environment for the ATDMA upstream and EuroDOCSIS downstream annex A
 - Gain could be close to a single order for the DOCSIS J.83 annex B downstream
- Defines new cable spectrum band plan
 - Upstream may extend to 200 MHz (D3.0 defines 5-85 MHz)
 - Downstream may extend to 1.2 GHz or 1.7 GHz (D3.0 defines 1 GHz)

Drivers for D3.1

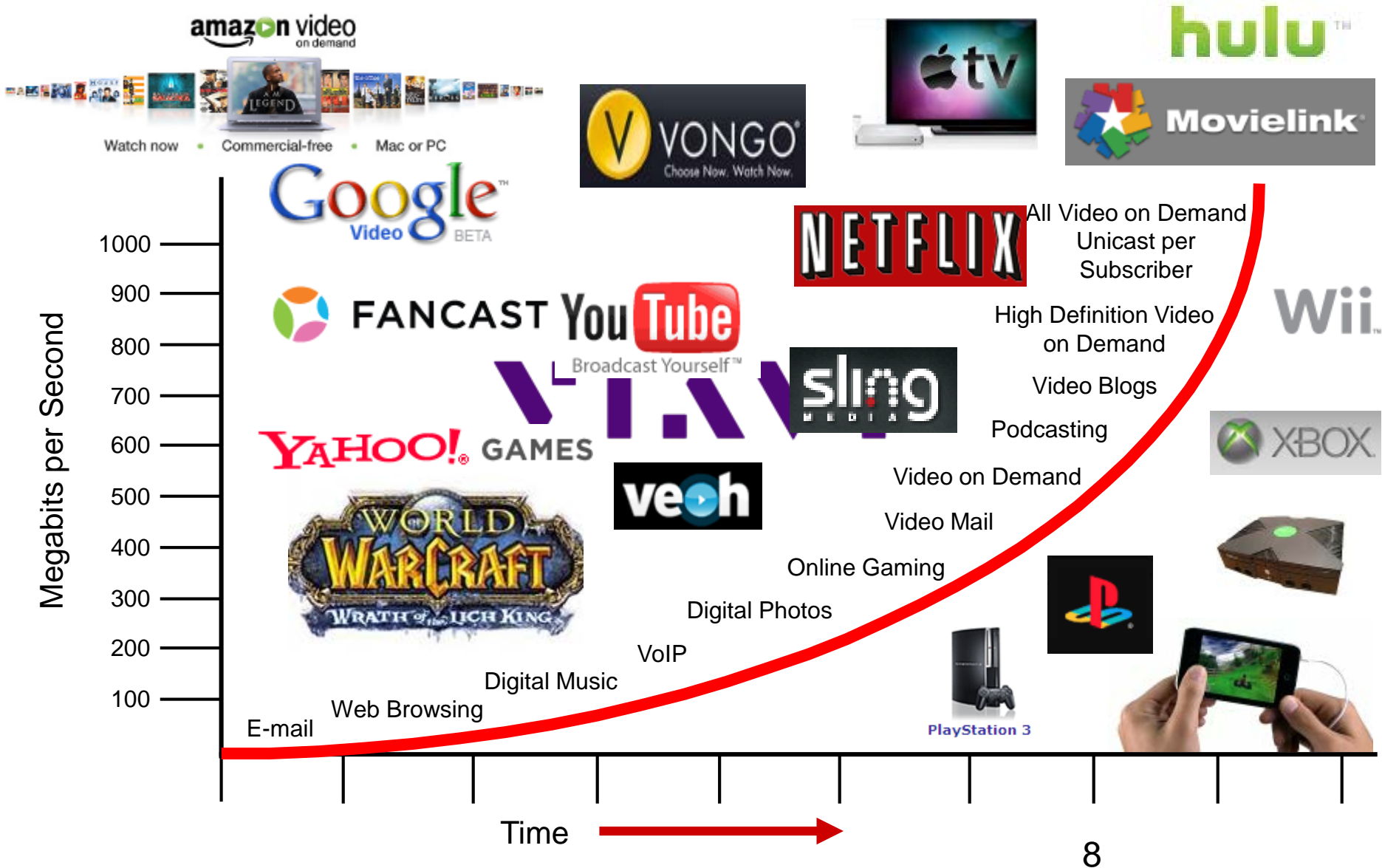

Increased demand for Bandwidth

- Adding bandwidth through two different ways
 - Increasing Capacity by adding Megahertz – plant extensions
 - Increasing efficiency by more bits/Hz – OFDM & LDPC
 -

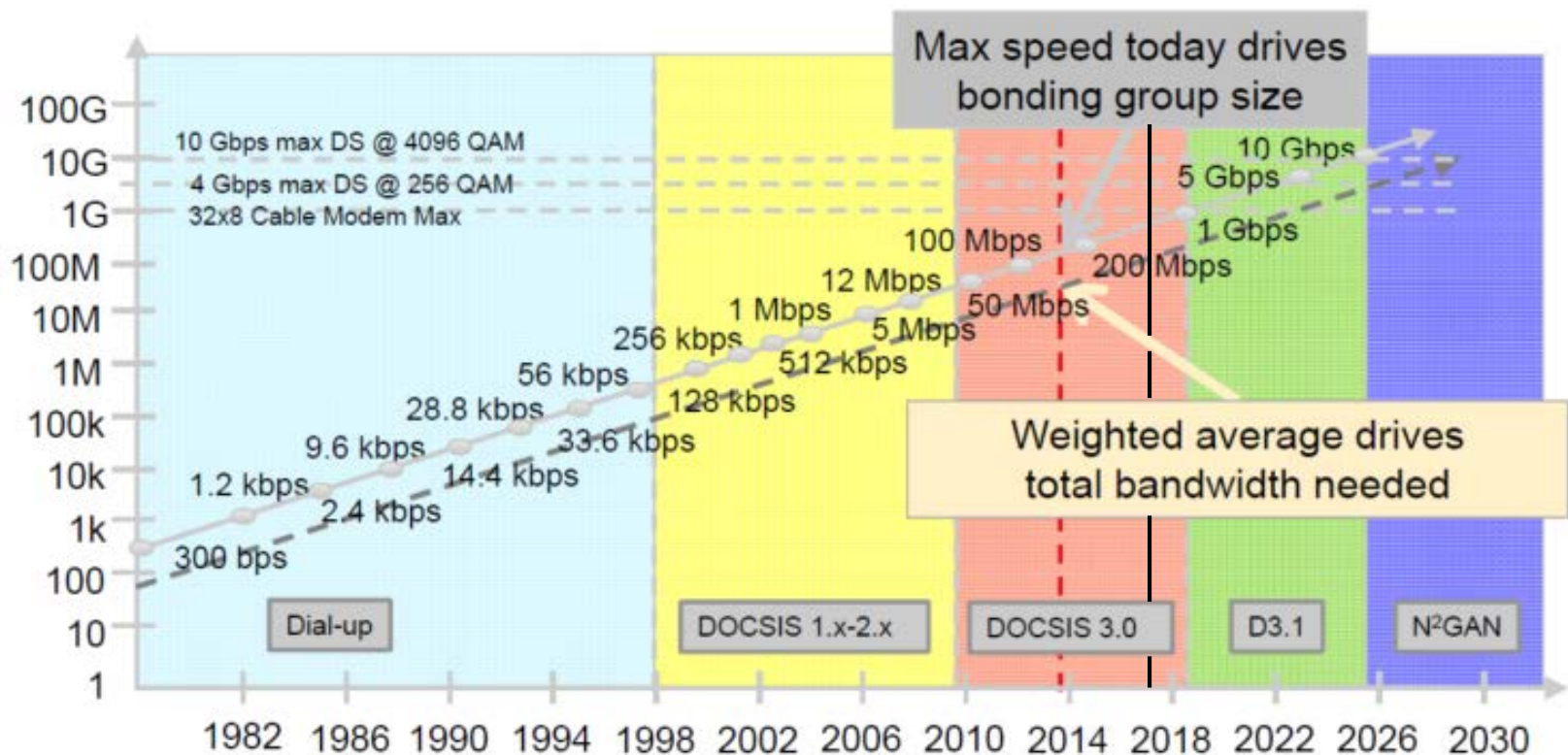

Source: Ben Finkelshtein, CEO webinar 1/17/15

D3.1 Hurdles

- Clear large chunks of spectrum for OFDM carriers
- Converting to all digital carriers, eliminating analogs.
- Completely new standards with new requirements
- New Tools for testing and system monitoring
- Mid splits and Frequency extensions
- MoCA interference if extending downstream to 1.2 GHz
- Training

Goals of 3.1

- Increase spectral efficiency (more bits / hertz)
- Increase speeds to 10GBs downstream and 1GBs upstream
- Adapts to different spectrum and plant conditions
- Easy migration from current version of DOCSIS
- Operates on existing HFC systems

D 3.1 Key Features

- Expanded Bandwidth
- Advanced Modulation
- Better Error Correction
- Co Existence with legacy DOCSIS
- PNM Tools
- Energy Management
- Eliminates 6 and 8 MHz channel standards
 - NA and Europe now same standard
- Backward compatibility with older versions of DOCSIS

Frequency Extensions

DS Extensions

- **1.2GHZ**
 - *DOCSIS 3.1 supports plant expansions to 1.2GHz. The D3.1 CM & CMTS must support 1.2GHz*
- **1.794 GHz**
 - *DOCSIS 3.1 support for 1.7GHz is optional for the CM & CMTS. be supported in a later version.*

US Extensions

- **85MHz QAM or OFDM**
 - *DOCSIS 3.1 supports 85 MHz upstream just like D3.0*
- **117MHz – for OFDM**
 - *DOCSIS 3.1 adds additional support for 117 MHz return*
- **204MHz – for OFDM**
 - *DOCSIS 3.1 adds optional support for a 204MHz return*

Expansion Summary

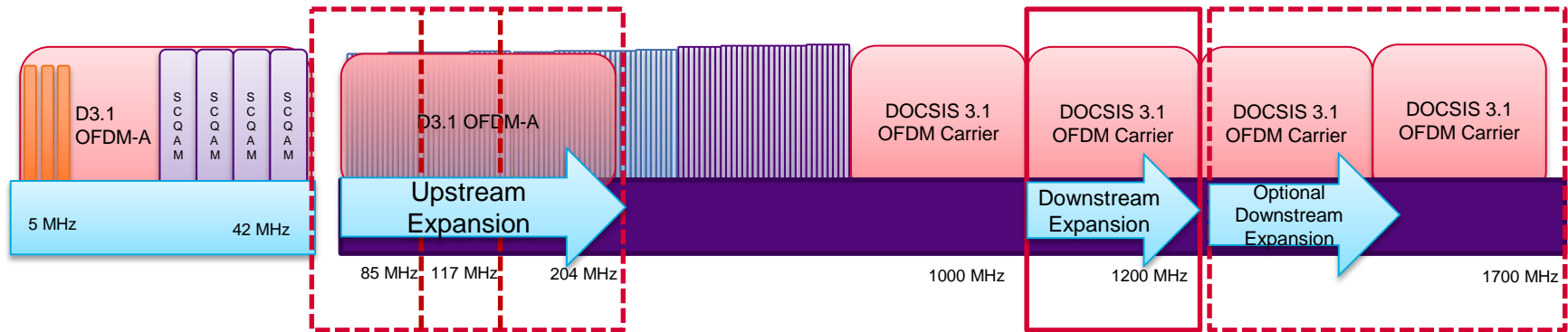

- Frequency expansion desirable but not necessary
- Downstream OFDM carriers are from 24 MHz to 192 MHz wide
- Downstream expands to as far as 1.7 GHz
- Upstream OFDMA carriers are up to 2 96 MHz wide carriers
- Upstream expands to as far as 204 MHz
- Coexistence with legacy carriers
- Typically <250 end devices per node

Some Mid Split Issues to ponder

- D3.1 modems transmit up to 65 dBmV
 - Home splitter isolation
- TV IF 41 – 47 MHz
 - Tuner RF isolation
- FM band ingress in the return path
- Signal egress in the aeronautical band from the upstream carriers
- Downstream OOB STB carriers
- Upstream Tilt and Equalization

DOCSIS 3.0 / 3.1 Speeds and Frequencies

Downstream	DOCSIS 3.0		DOCSIS 3.1	
	Initial	Futures	Initial	Futures
DS Range (MHz)	54 - 1002	108 - 1002	252 - 1212	504 - 1700
DS QAM Level	256	256	256 - 4096	256 - 16,384
# DS Channels	8	24	5 x 192 MHz	6 x 192 MHz
DS Capacity (bps)	300M	1G	8G	10G

New Carriers – OFDM & OFDM-A

OFDM

- Orthogonal Frequency Division Multiplexing
- Multi-Carrier Technology
- Composed of “Subcarriers”
- FFT-Based Implementation

Legacy DOCSIS SC-QAM

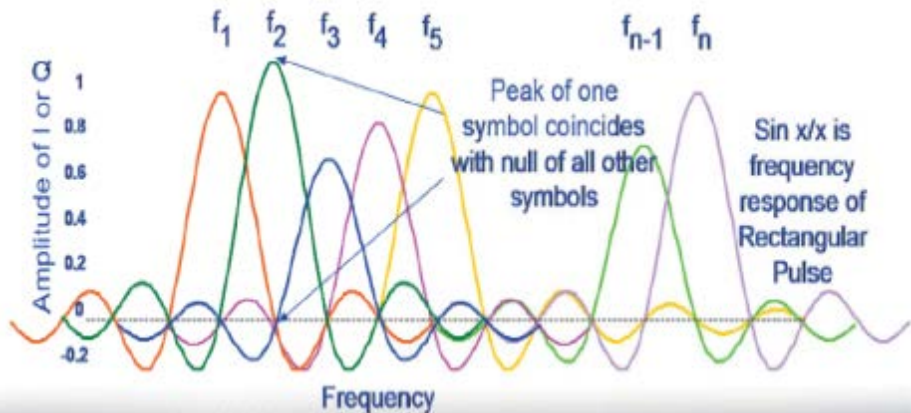
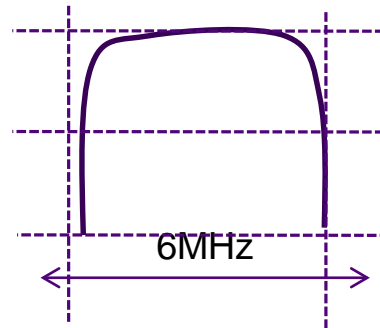

← 192MHz →

Why OFDM?

- OFDM has been around for a while and is a proven technology
- OFDM carriers can be from 24 to 192 MHz wide in 6 MHz increments.
- Up to 5 192 MHz wide carriers
- Longer Symbol Times
- Better spectrum efficiency
 - Carriers up to the edge of the channel and no guard bands
- Better spectrum utilization through bit loading
- Flexible Modulation schemes
 - Different modulation schemes based on cable modem performance
 - Level of Modulation is based on MER at the CPE

OFDM

Orthogonal Frequency Division Multiplexing

- OFDM uses individual narrowband sub-carriers
- Sub carriers can be spaced at either 25 or 50 KHz in the downstream. Or there could be as many as 8000 sub-carriers spaced at 25 KHz each within a 192 MHz wide downstream carrier.
- For even greater spectral efficiency, these subcarriers actually overlap in spectrum.
- Each sub carrier can be turned off where there are interference issues or legacy carriers are present.
- Each sub carrier has it's own modulation level
- Guard bands are eliminated therefore we gain bandwidth and can transmit more bits per hertz.
- The carriers are distinguishable from each other because they are mathematically orthogonal, meaning non-interfering.
- Sub carrier frequencies are chosen with the exact minimum spacing that make them orthogonal.

Instantaneous Inverse Fast Fourier Transform

- A rectangular pulse in terms of time transforms into a $\frac{\sin X}{X}$ carrier in the frequency domain
- The $\frac{\sin X}{X}$ carrier has regularly spaced nulls in the frequency domain

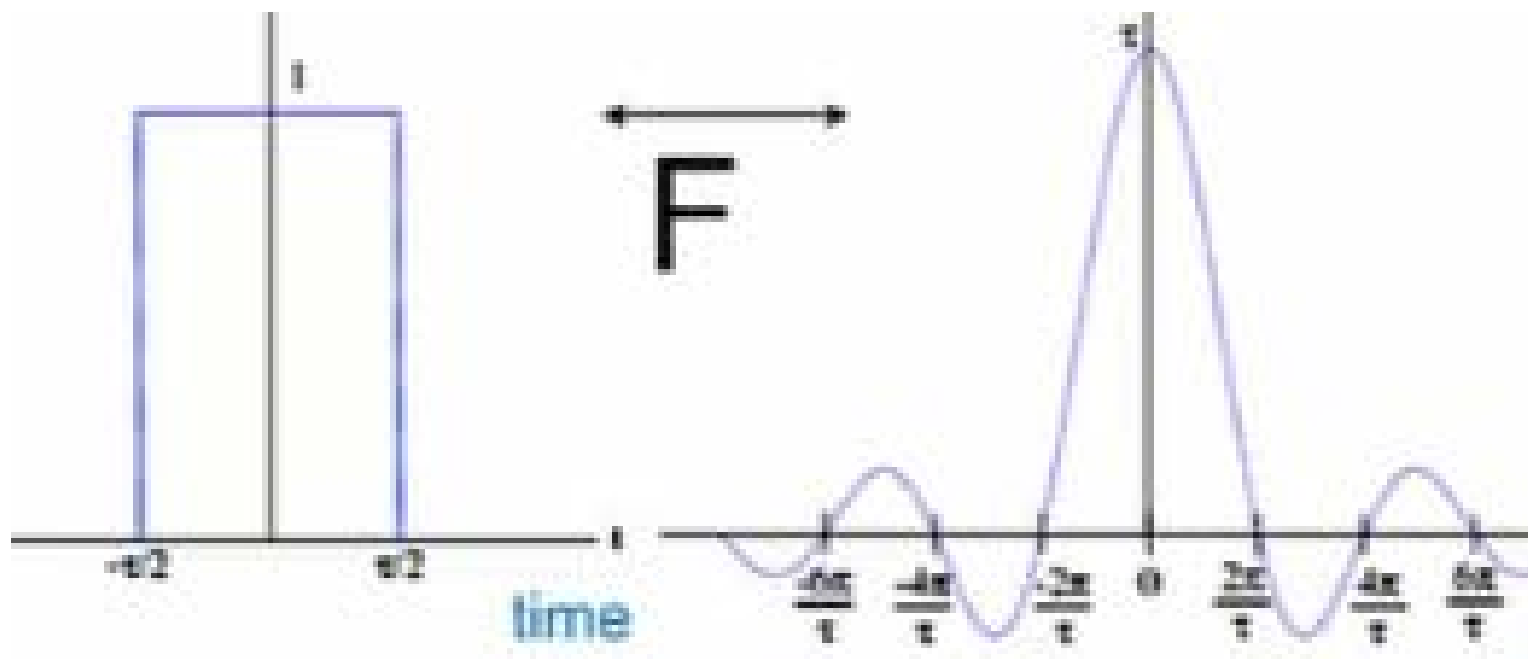

OFDM

- Orthogonal Frequency Division Multiplexing
- Radical departure from single carrier QAM of D3.0
- Quadrature Amplitude Modulation (QAM) of a set of 4k/8k orthogonal carriers overlapping in time

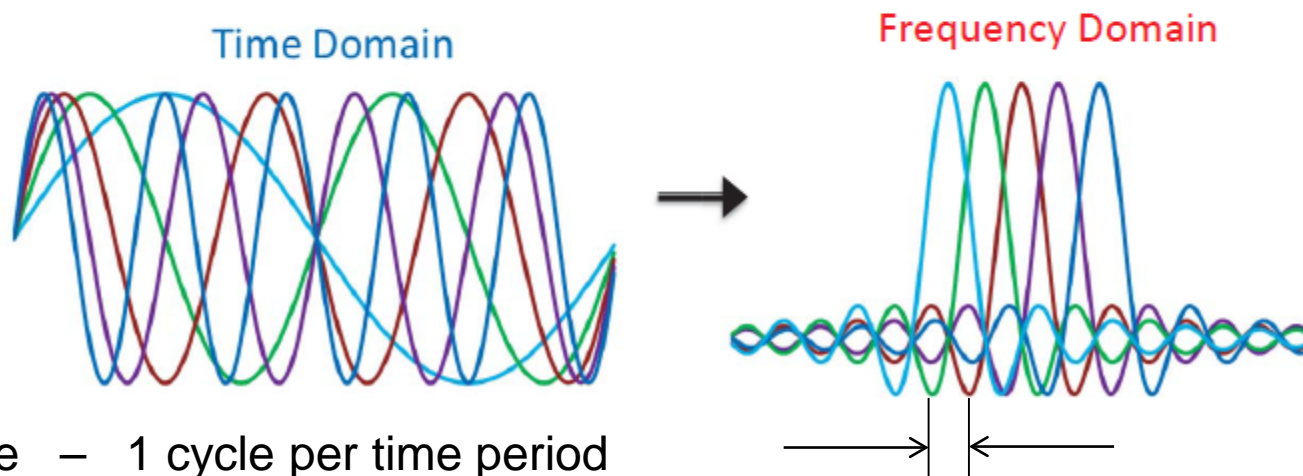

Blue – 1 cycle per time period
Green – 2 cycles per time period
Red – 3 cycles per time period

Sub carrier spacing is
Equal to $1/T_{FFT}$

Subcarrier Modulation

- Subcarriers can be defined to be on either a 25kHz spacing or a 50kHz spacing
- For a 192MHz OFDM carrier this means there are either
 - 4096 subcarriers – 50kHz spacing, 4k FFT
 - 8192 subcarriers – 25kHz spacing, 8k FFT
- Each of these subcarriers can have a different order of QAM modulation

DS Data Modulation Formats
16-QAM
64-QAM
128-QAM
256-QAM
512-QAM
1024-QAM
2048-QAM
4096-QAM
8192-QAM - Optional
16384-QAM - Optional

BPSK and QPSK are used for the PLC and NCP only

OFDM Sub Carriers

- Requires tight timing and frequency synchronization between transmitter and receiver!

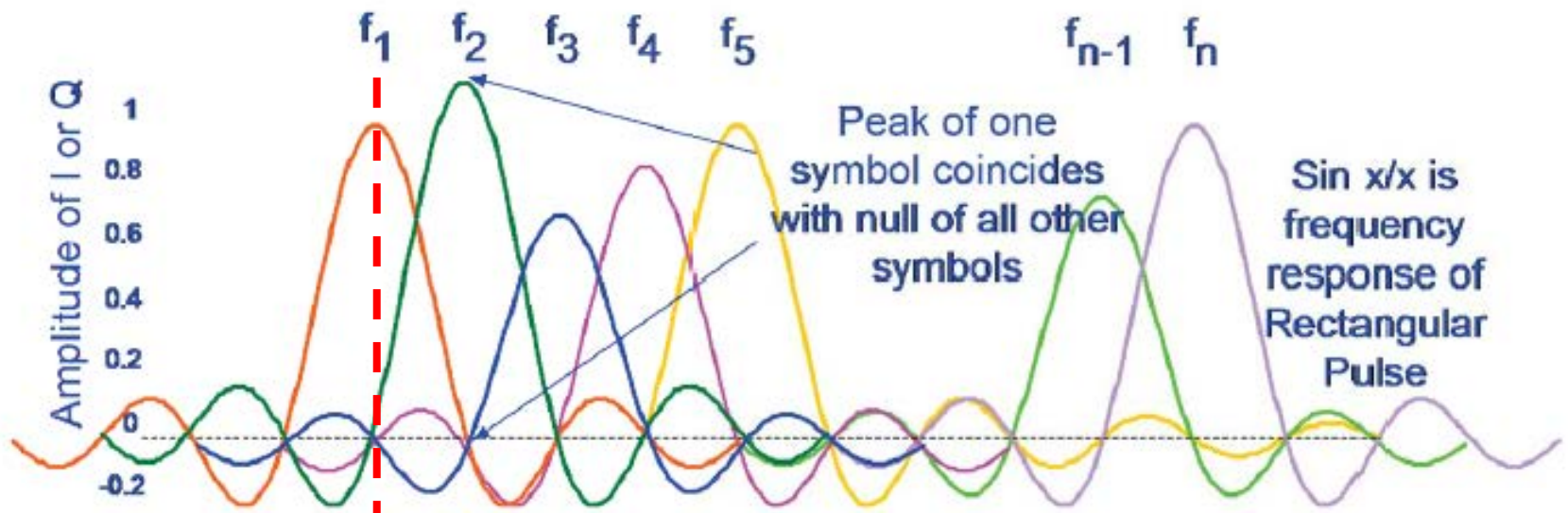

Advantages - Variable Bit Loading

- Simply means that different levels of QAM can be assigned to individual sub carriers.
- Higher orders of QAM carry more bits/hertz
 - 256 QAM is 8 bits/symbol
 - 4096 QAM is 12 bits/symbol
- Different Bit Loading with different Modulation Profiles
- Use higher order of QAM with better plant performance

Constellation

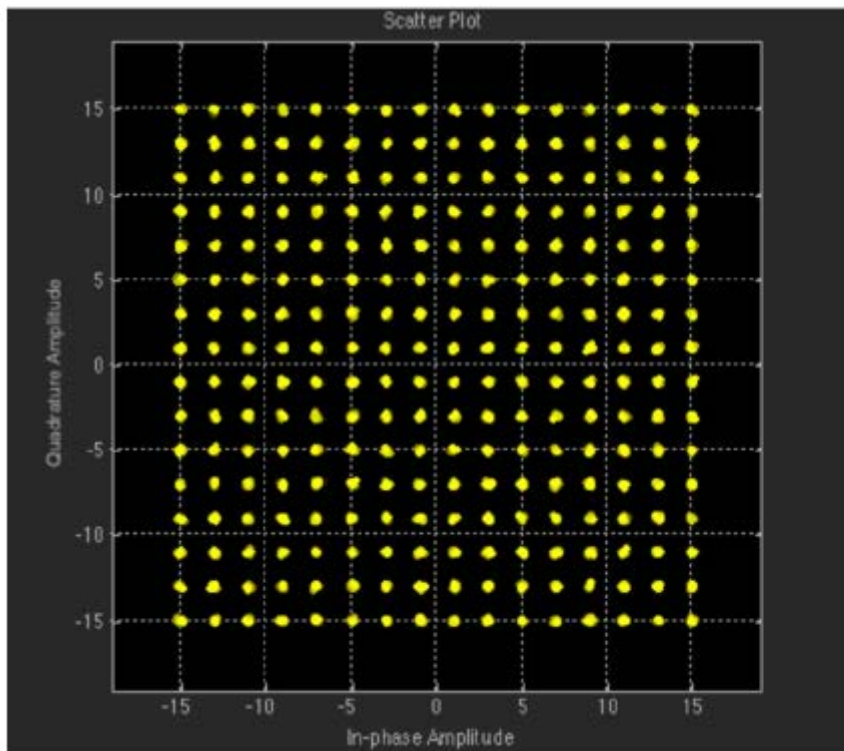

256 QAM

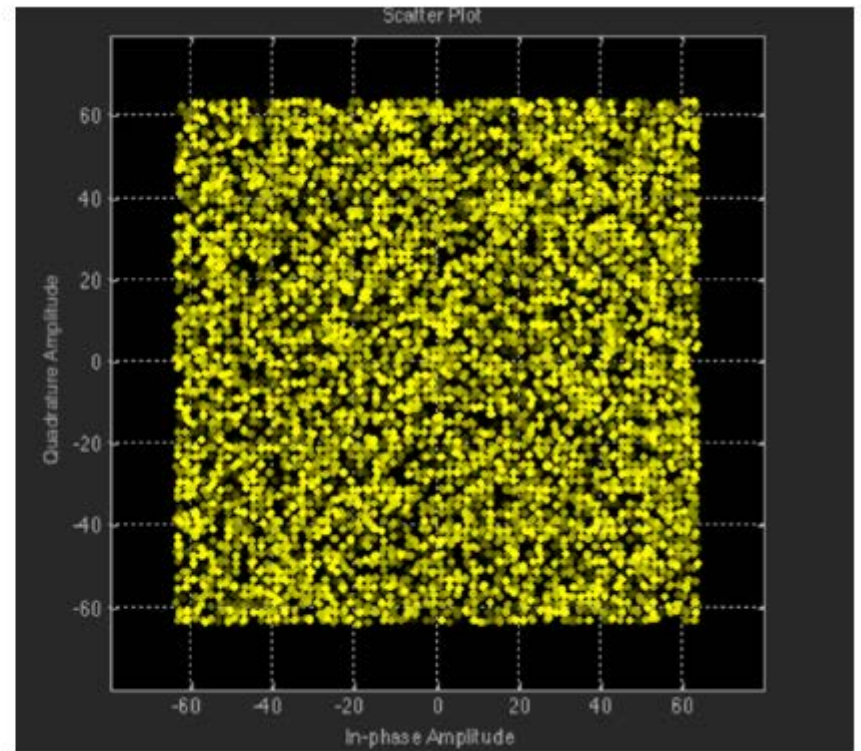

4096 QAM

Advantages - More Bits per Hertz

No wasted bandwidth with guard bands in OFDM.

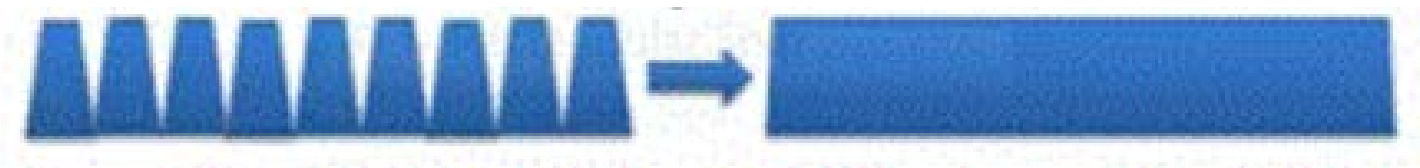

Advantages - OFDM has Longer Symbol Times

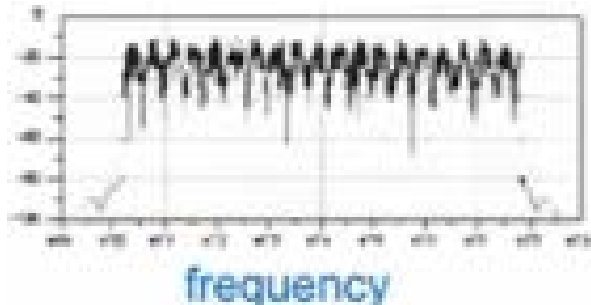

- Narrower Sub-Carriers mean longer symbol times
- Symbol Time of a 192 MHz wide carrier has a symbol time of about 80 μ Sec. A 6 MHz single 256 QAM carrier has a .2 μ Sec symbol time.
- As an example, reflections separated by 100' have a reflection time of .234 μ Sec. That easily interferes with a .2 μ Sec symbol whereas not so much with an 40 μ Sec symbol time.
- Benefits of longer symbol times
 - Easier interleaving and error control coding
 - Better resilience against micro reflections
 - Better resilience against upstream bursts and impulse noise

Modulation – SC QAM

One Symbol, 8 bits for 256 QAM

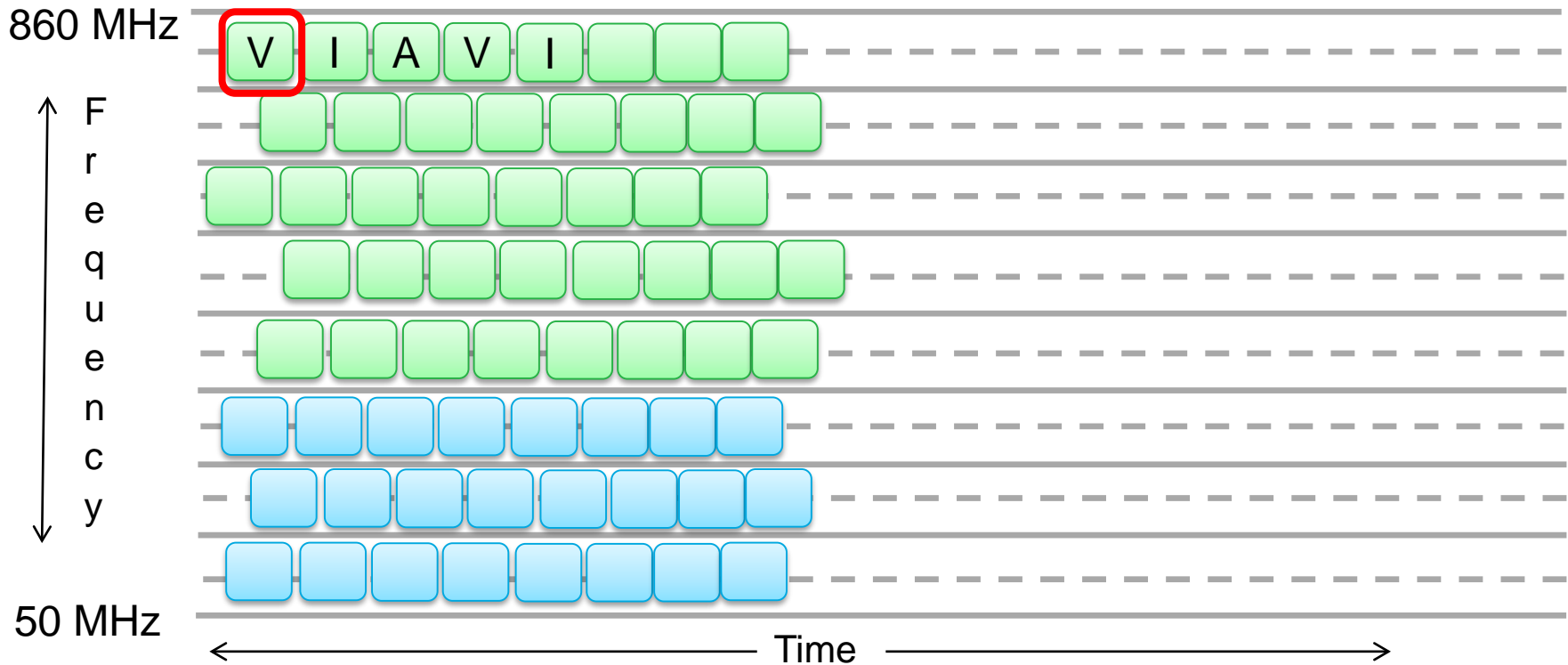

- Dedicated 6MHz Channels (8MHz in EMEA)
- Each Frequency behaves independently
- Symbols happen sequentially within the channel
- Modulation is optimized for the worst part of the plant
- Each symbol is about 2 μ Sec in duration

OFDM – Orthogonal Frequency Domain Multiplexing

Subcarriers and symbols

Cyclic Prefix Time

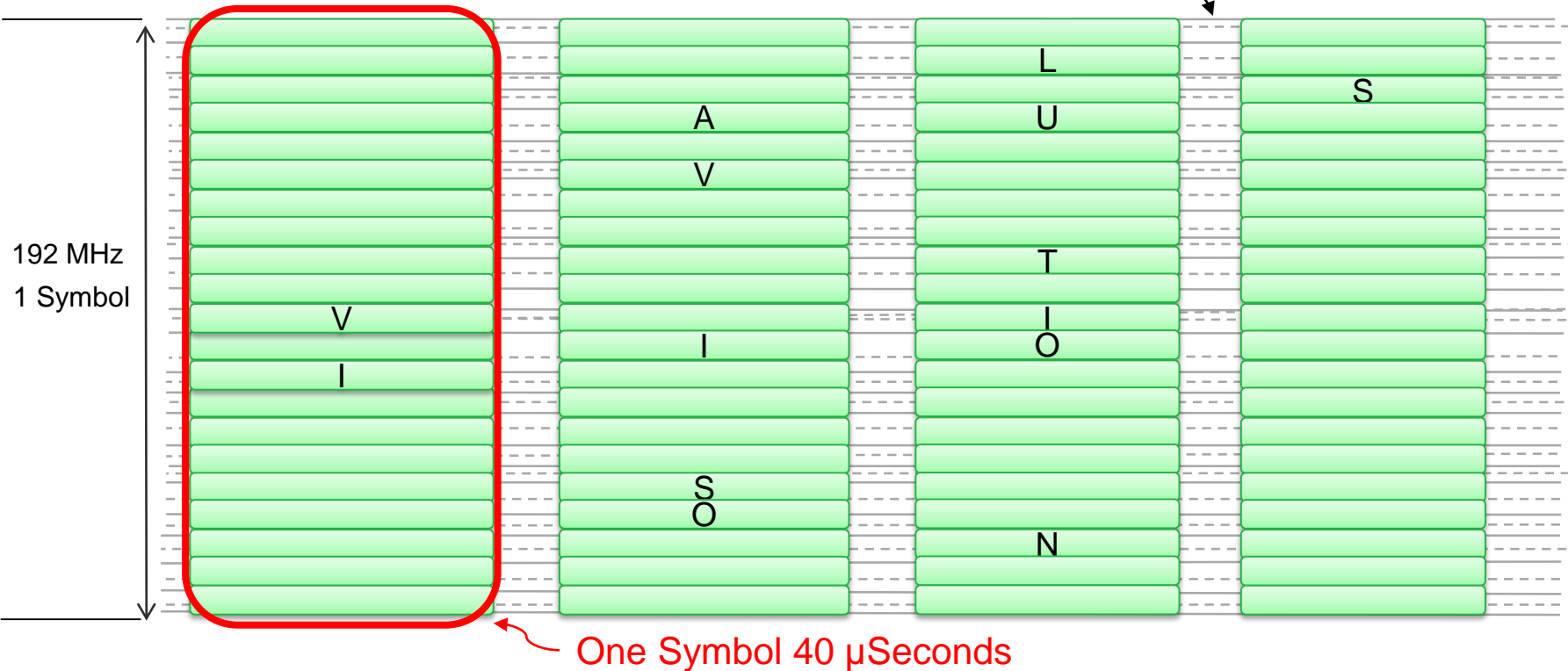

- OFDM uses 25kHz or 50kHz subcarriers spread across the entire bandwidth of the carrier
- In the above example, a 192MHz OFDM Carrier w/ 25kHz spacing, there are 8000 subcarriers
- All subcarriers are time synchronized across the entire bandwidth of the carrier
- Each subcarrier has its own modulation type (64 QAM, 256 QAM, 1024 QAM, 4096 QAM etc)
- Demodulation is FFT (Fast Fourier Transform) based so time synch is critical
- Codewords are spread across multiple subcarriers and multiple time slots (symbols)

Exclusions

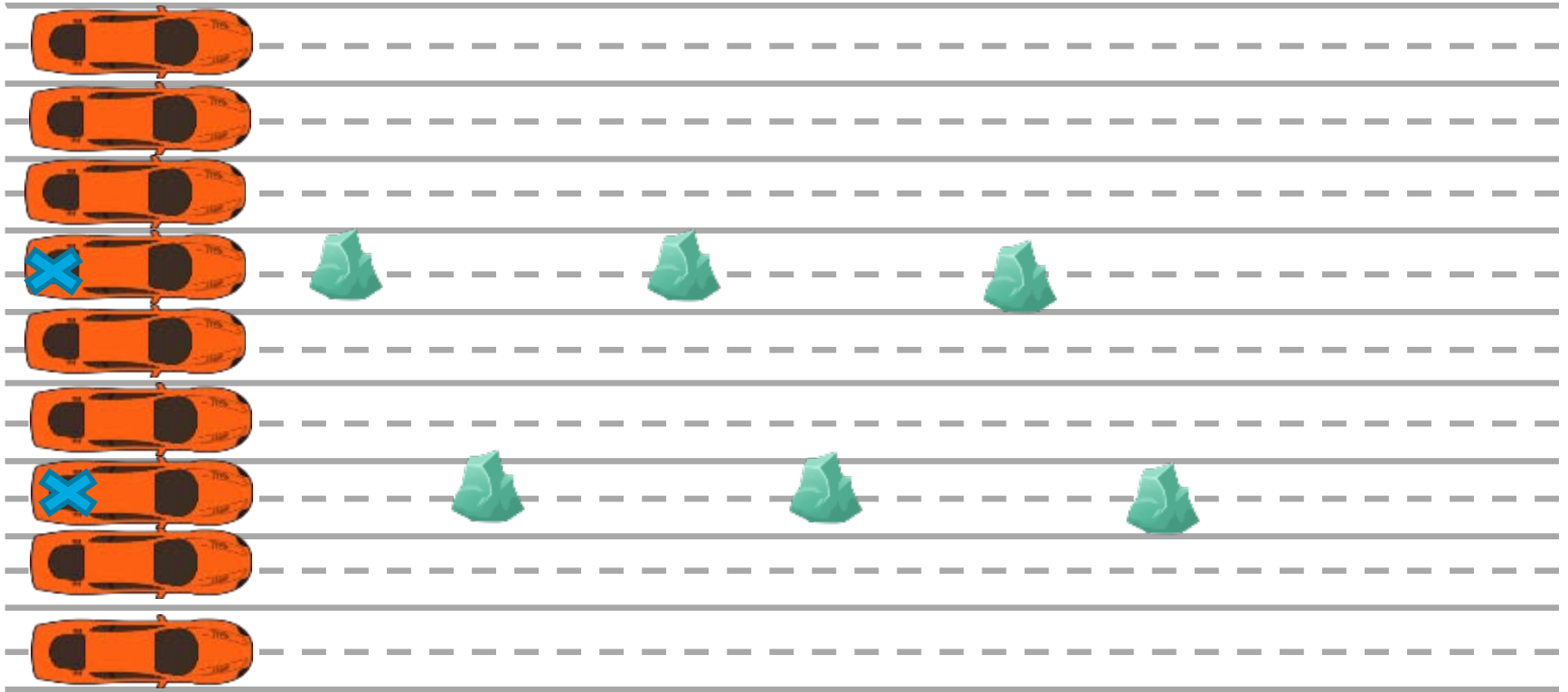

- OFDM allows for the ability to exclude specific subcarriers.
- At least 2 MHz of data spectrum between Exclusion Bands
- Exclusion bands must be at least 1 MHz wide and less than 20% of the OFDM carrier spectrum.

DOCSIS 3.1 Downstream Profiles

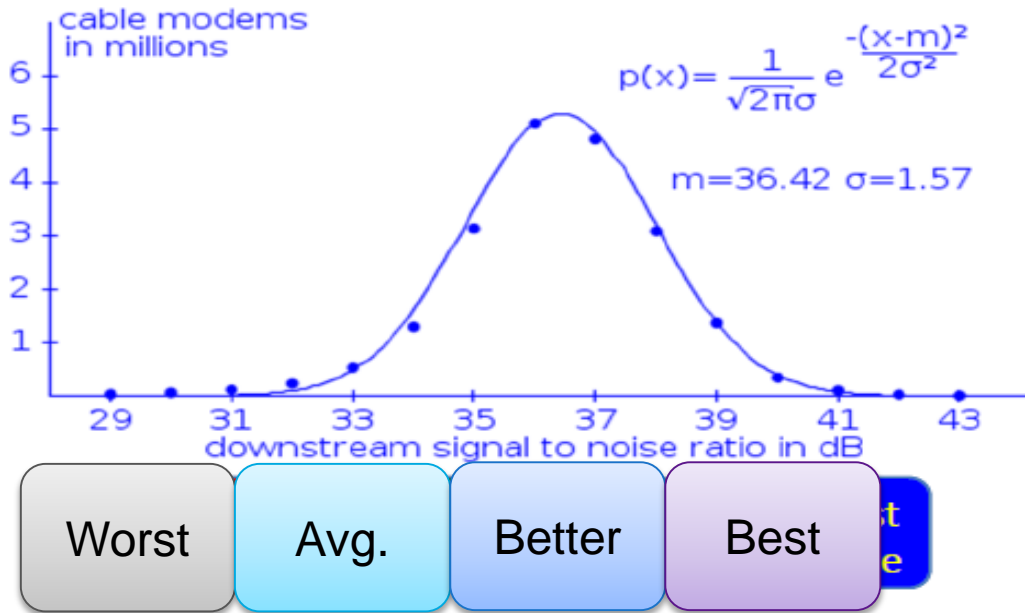

Tailor profiles to account for SNR differences in the plant

Worst – (mostly 256 QAM)
Avg. – (mostly 1024 QAM)
Better (mostly 2048 QAM)
Best (mostly 4096 QAM)

Some CM's can do better than others – so let them

Net capacity is higher than the “least common denominator”

- Profiles maximize traffic capabilities over varying plant conditions
- Modifies the bit loading on each sub-carrier
- Maximizes data efficiency

Required Minimum SNR for different orders of QAM

Order of QAM	Minimum MER Threshold	SNR Range
4096	36 dB	>38
2048	33 dB	35-38 dB
1024	30 dB	32-35 dB
512	27 dB	29-32 dB
256	24 dB	15-29 dB

Downstream Profiles

- A profile is a list of modulations that are used for the subcarriers within an OFDM Channel. Determines Bit Loading of the each of the sub carriers.
- The downstream can use different profiles for different groups of CM's.
- Typically, a group of CM's that have similar SNR performance will be grouped into the same profile

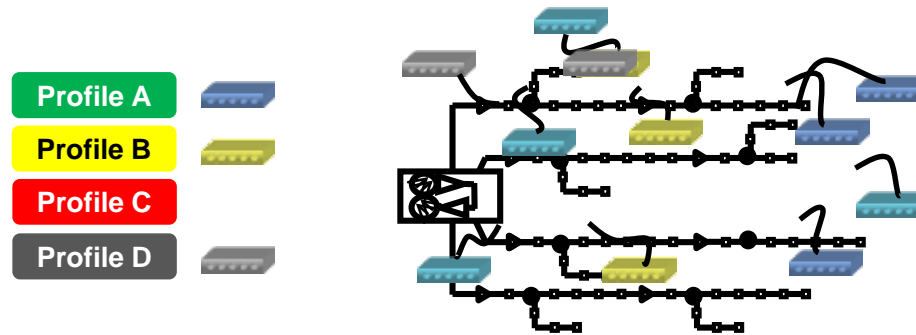

- **Profile A:** This is the boot profile that a CM first receives when it is initializing
 - All CM's have to be able to receive Profile A
 - Additional profiles will utilize higher modulations
 - The overall network efficiency and capacity goes up with more customers being able to utilize the higher profiles

How are Profiles Established?

- Not addressed by the D3.1 specifications

Static

- Operators configure Profiles in the CMTS
 - Manually done by known plant and modem performance
 - Duplicate Profiles from other markets
 - Helper functions from CMTS manufacturers or 3rd party vendors

Dynamic

- As PNM data is analyzed and Profiles are changed based on CM performance
- Profiles vary slowly, not intended to handle short term events
 - If a single modem has a problem, then that modem moves to a lower Profile
 - If many modems have a problem, the profile is changed

Modulation Profiles – basic concept

Simplified for conceptual purposes

Legend



- 256 QAM
- 1024 QAM
- 2048 QAM
- 4096 QAM

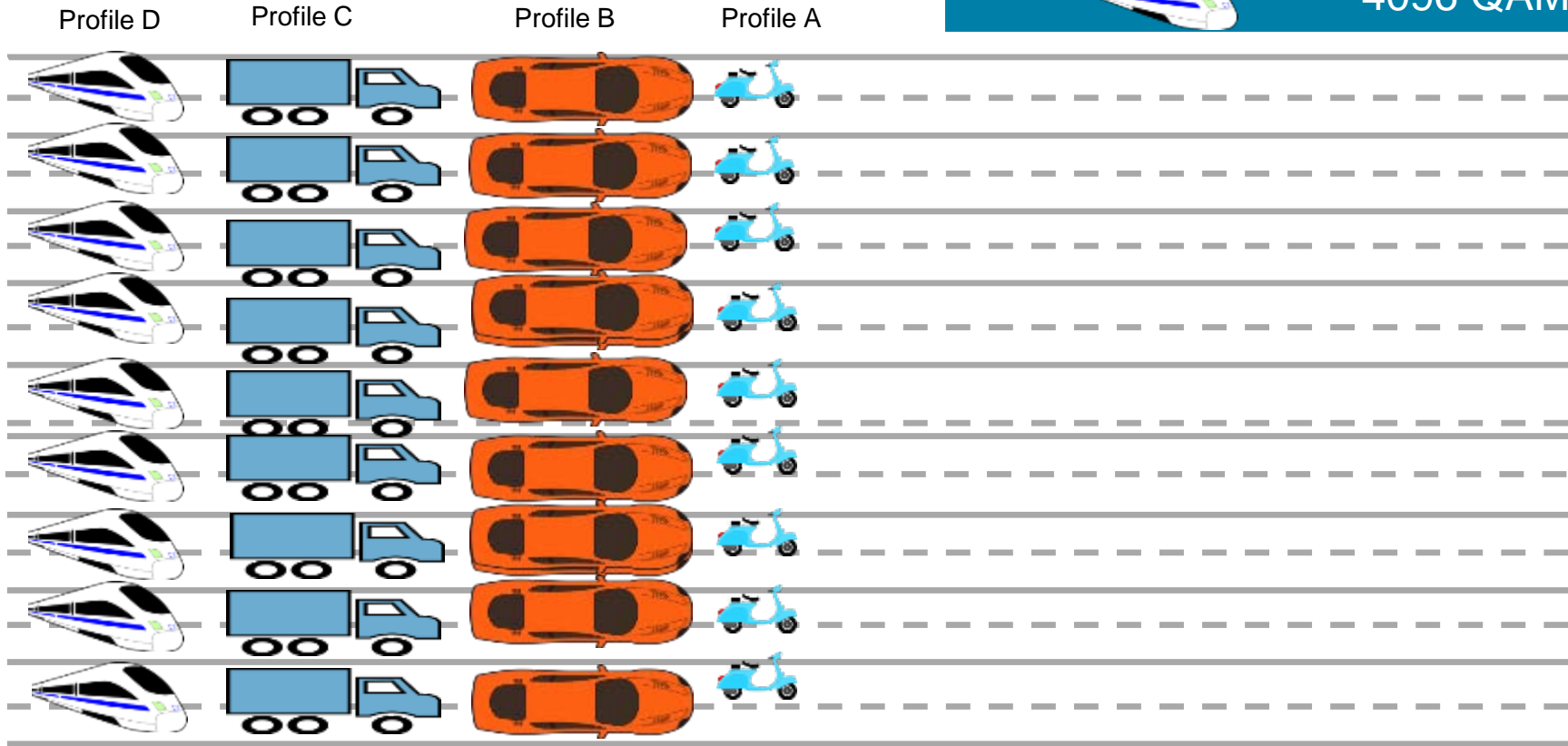

For simplicity sake, let's assume that the profiles use the same modulation for all subcarriers.

Profiles – realistic concept

Simplified for conceptual purposes

Legend



256 QAM
1024 QAM
2048 QAM
4096 QAM

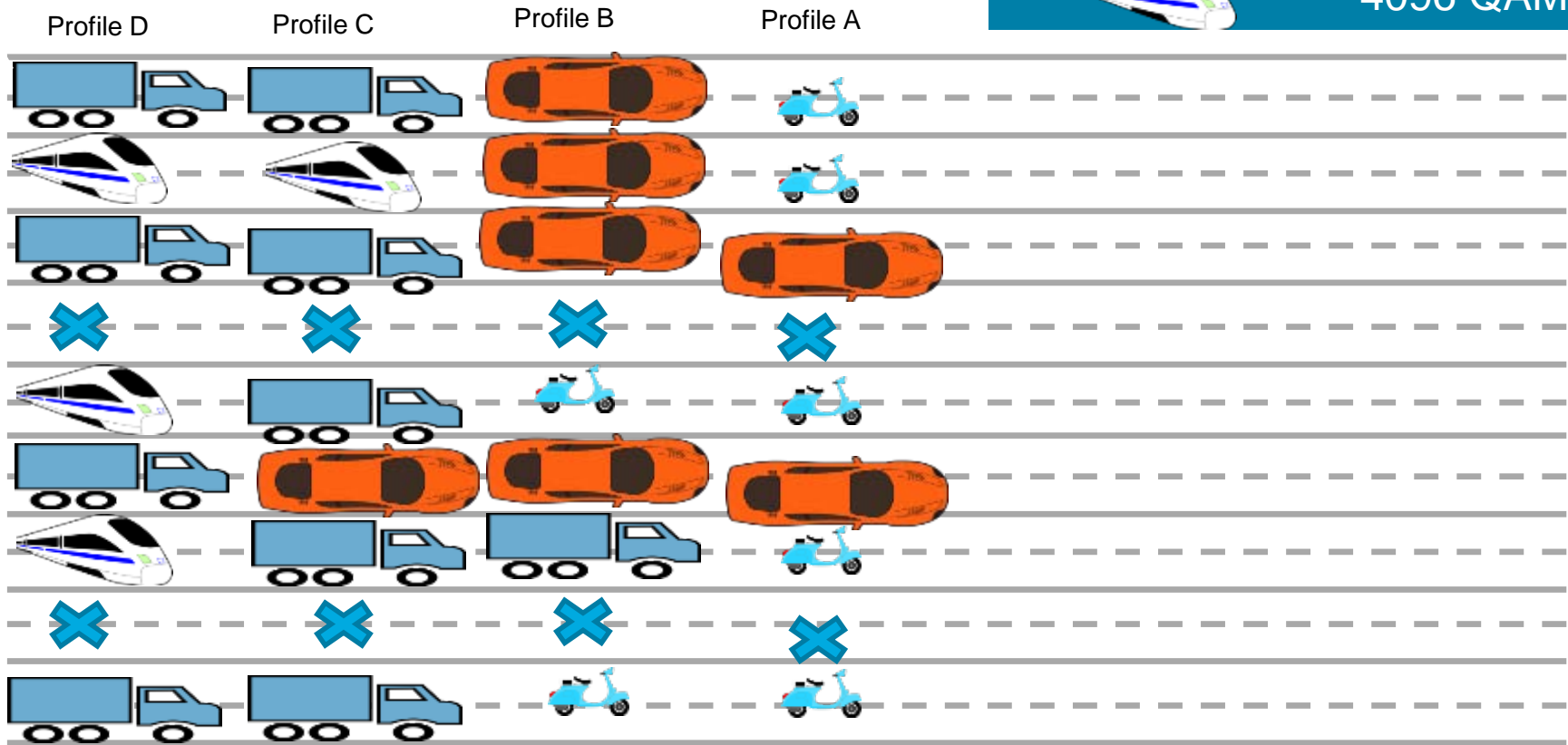

OFDM allows for the ability to exclude specific subcarriers. It also allows each profile to vary the modulation on each subcarrier.

This allows the ability to optimize the overall carrier performance. Each profile have the same exclusions.

LDPC Error Coding

DS Spectrum (MHz)	Plant SNR (dB)	SNR after MSO Margin (dB)	D3.1 QAM Bits	D3.1 DS Throughput (Gbps)	D3.0 DS Throughput (Gbps)	Gain %
54-1000	36.4	32.4	11	8.8	6.1	43.6
54-1000	39	35	12	9.6	6.1	56.7
54-1000	41	37	12.5	10	6.1	63.2
54-1700						
54-1700	36.4	32.4	11	15.3	6.1	149.9
54-1700	39	35	12	16.7	6.1	172.6
54-1700	41	37	12.5	17.4	6.1	184

Source: Arris, CED DOCSIS 3.1 webinar 11/2013

Low Density Parity Check (LDPC) Forward Error Correction:

Previously too complex to implement

Gets more bits/Hz

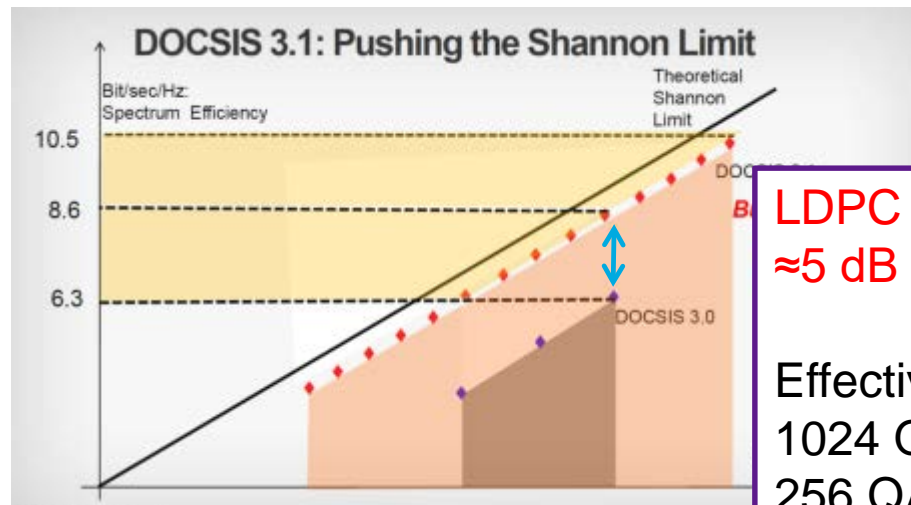

LDPC provides ≈ 5 dB of SNR gain

Effectively gets: 1024 QAM where 256 QAM with RS

Source: Cable Congress 2013: HFC Readiness for DOCSIS 3.1 Kabel Deutschland

Forward Error Correction LDPC

Instead of adding bits for RS, now there are codes at the end of a number of bits with position of the 1s in the row.

$$H = \begin{matrix} & \begin{matrix} V1 & V2 & V3 & V4 & V5 & V6 & V7 & V8 & V9 & V10 & V11 & V12 \end{matrix} \\ \begin{matrix} C1 \\ C2 \\ C3 \\ C4 \\ C5 \\ C6 \end{matrix} & \begin{bmatrix} 0 & 0 & 1 & 0 & 1 & 0 & 0 & 1 & 0 & 1 & 0 & 0 \\ 1 & 0 & 0 & 0 & 1 & 0 & 0 & 0 & 1 & 0 & 1 & 0 \\ 0 & 1 & 0 & 0 & 0 & 1 & 1 & 0 & 0 & 0 & 1 & 0 \\ 0 & 0 & 1 & 1 & 0 & 0 & 1 & 0 & 0 & 0 & 0 & 1 \\ 1 & 0 & 0 & 0 & 0 & 1 & 0 & 1 & 0 & 0 & 0 & 1 \\ 0 & 1 & 0 & 1 & 0 & 0 & 0 & 0 & 1 & 1 & 0 & 0 \end{bmatrix} \end{matrix}$$

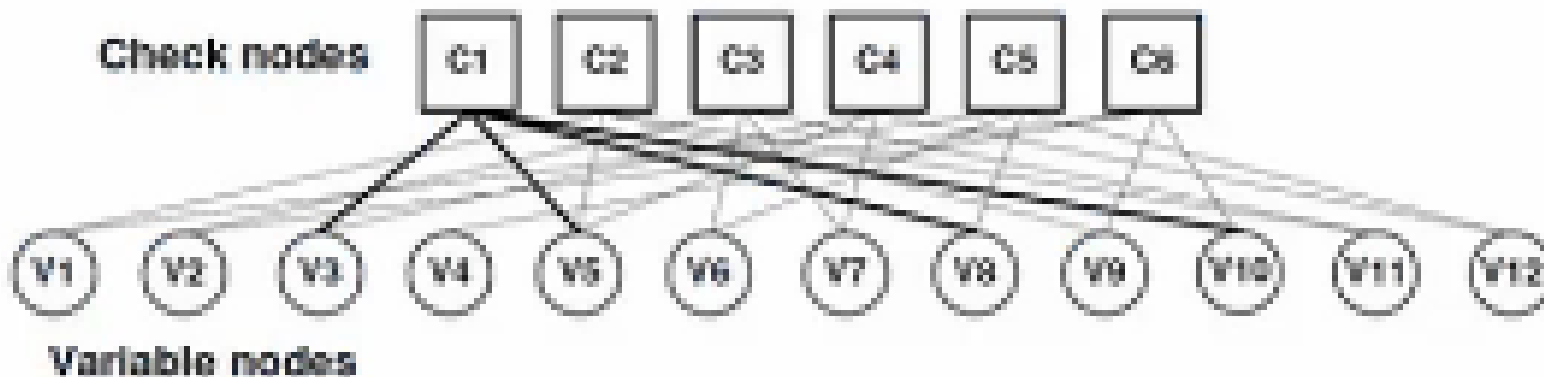

Error Correction – LDPC

Low Density Parity Check

- LPDC does add to the bandwidth



In the downstream, LDPC uses 16,200 bit codewords.

DOCSIS 3.1 Spectrum and Different Sub Carrier Types

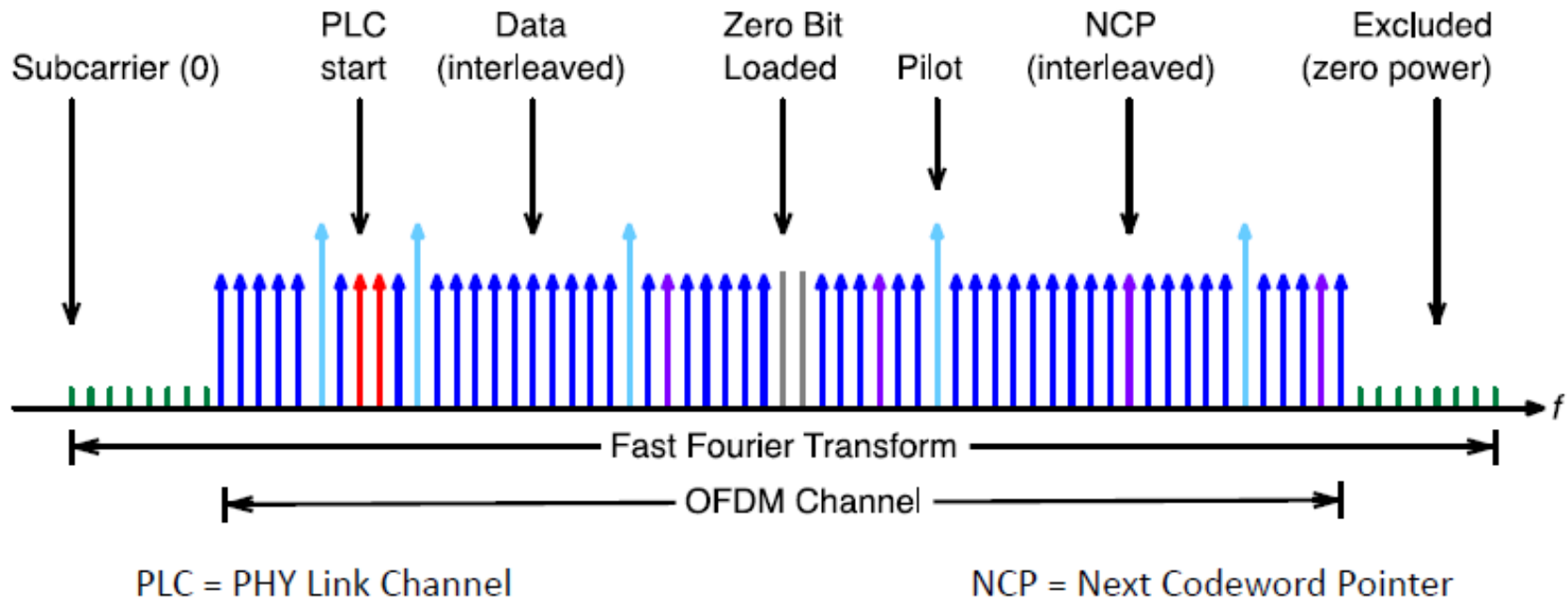

Sub Carrier Parameters

Parameter	Assumption Value	
Channel size	Synchronous 192 MHz with 190 MHz active spectrum	
Subcarrier spacing	25 kHz	50 kHz
FFT size	8K (8192)	4K (4096)
FFT duration	40 usec	20 usec
Subcarriers in 192 MHz	7,680	3,840
Active subcarriers in 190 MHz	7,600	3,800
Guard band (2MHz total)	80 subcarriers	40 subcarriers
Continuous Pilots	88	88
Scattered pilots	60	30
PLC subcarriers	16	8
CP duration	2.5 usec	
NCP subcarriers	48	
Effective FEC code rate	0.8785	

Physical Link Channel (PLC)

- PLCs are sub carriers known to the cable modem and carry information about the downstream Physical Layer.
 - Timestamp
 - Energy management
 - Trigger message for synchronizing an event between the CMTS and CM.
 - Message channel for bringing new CMs on line.
- Either 8 with 50 KHz or 16 with 25 KHz sub carriers wide and total 400 KHz within the OFDM carrier
- With surrounding Continuous Pilots a total of 6 MHz wide
- Placed in within the carrier, but not necessarily at the center
- Preamble is BPSK and the PLC itself is 16 QAM for robustness
- No exclusions in PLC bandwidth
- Without the PLC acquisition, the modem cannot decode data from the CMTS

OFDM – PLC over several symbols

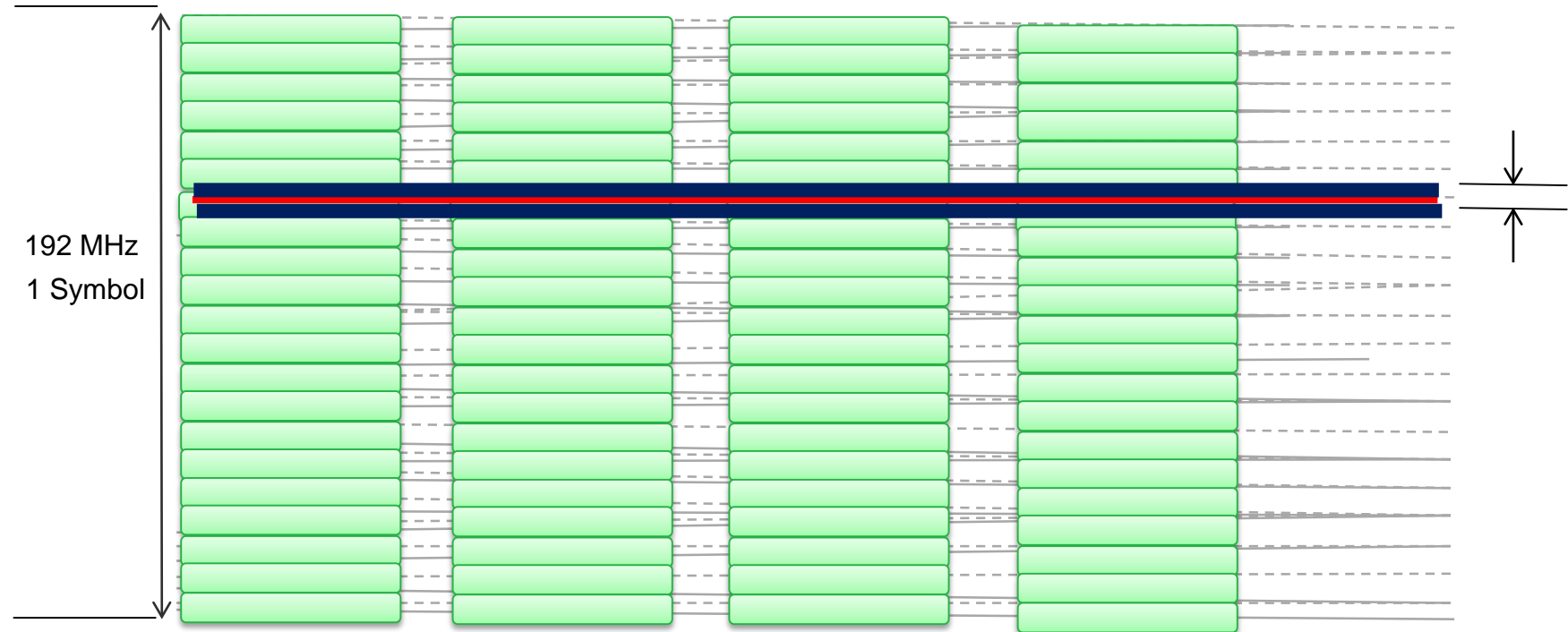

- 400 KHz PLC surrounding by Continuous Pilots, 6 MHz wide total
- PLC contains MAC Management Messages, MMMs:
 - OFDM Channel Descriptors
 - UCDs Upstream Channel Descriptors
 - MAPs Bandwidth Allocation Messages
 - DPDs Downstream Profile Descriptors
 - ODS OFDM Spectrum Descriptors

NCP – Next Codeword Pointer

- When data codewords are mapped to subcarriers within a symbol, a pointer is needed to identify where a data codewords start.
- The Main task of the NCP message block is to provide a reference to the appropriate profile and a start pointer for codewords.
- The NCP MUST use one of three modulation formats

NCP Modulation	# of Subcarriers
QPSK	24
16-QAM	12
64-QAM	8

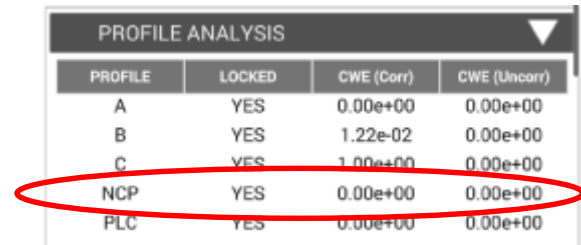

The image shows a screenshot of a 'PROFILE ANALYSIS' table. The table has four columns: PROFILE, LOCKED, CWE (Corr), and CWE (Uncorr). The rows are A, B, C, NCP, and PLC. The NCP row is circled in red. The values for the NCP row are: PROFILE: NCP, LOCKED: YES, CWE (Corr): 0.00e+00, and CWE (Uncorr): 0.00e+00.

PROFILE	LOCKED	CWE (Corr)	CWE (Uncorr)
A	YES	0.00e+00	0.00e+00
B	YES	1.22e-02	0.00e+00
C	YES	1.00e+00	0.00e+00
NCP	YES	0.00e+00	0.00e+00
PLC	YES	0.00e+00	0.00e+00

It is critical that the NCP does not have uncorrectable code word errors.

NCP – Next Codeword Pointer

- OFDM maps codewords, to subcarriers within and across different symbols.
- To perform this a pointer is needed to identify where a data codewords start.
- This is known as the Next Codeword Pointer (NCP)
- There are a variable number of NCP message blocks (MBs) on each OFDM symbol

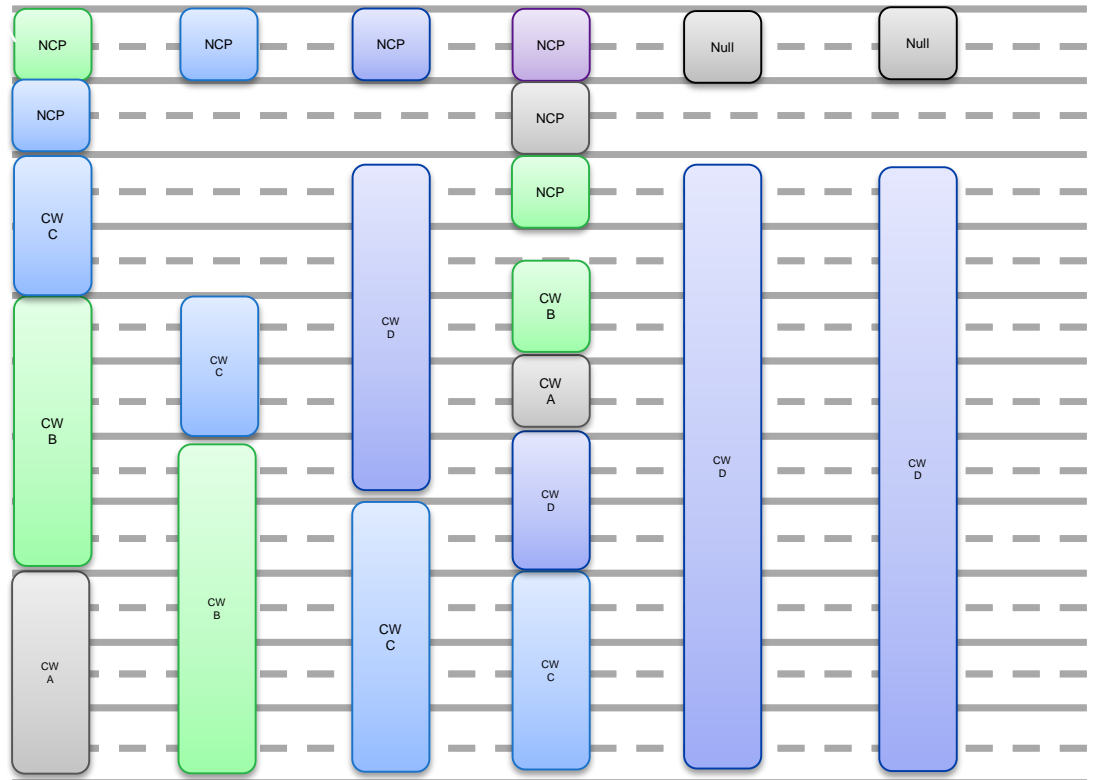
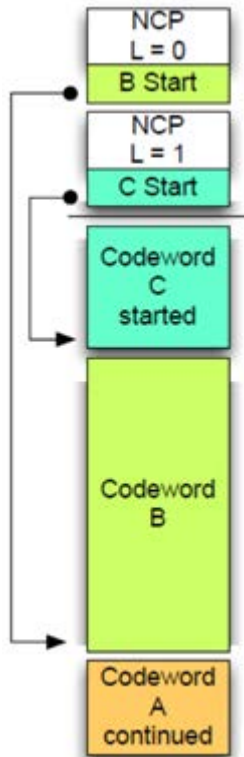

Continuous Pilots

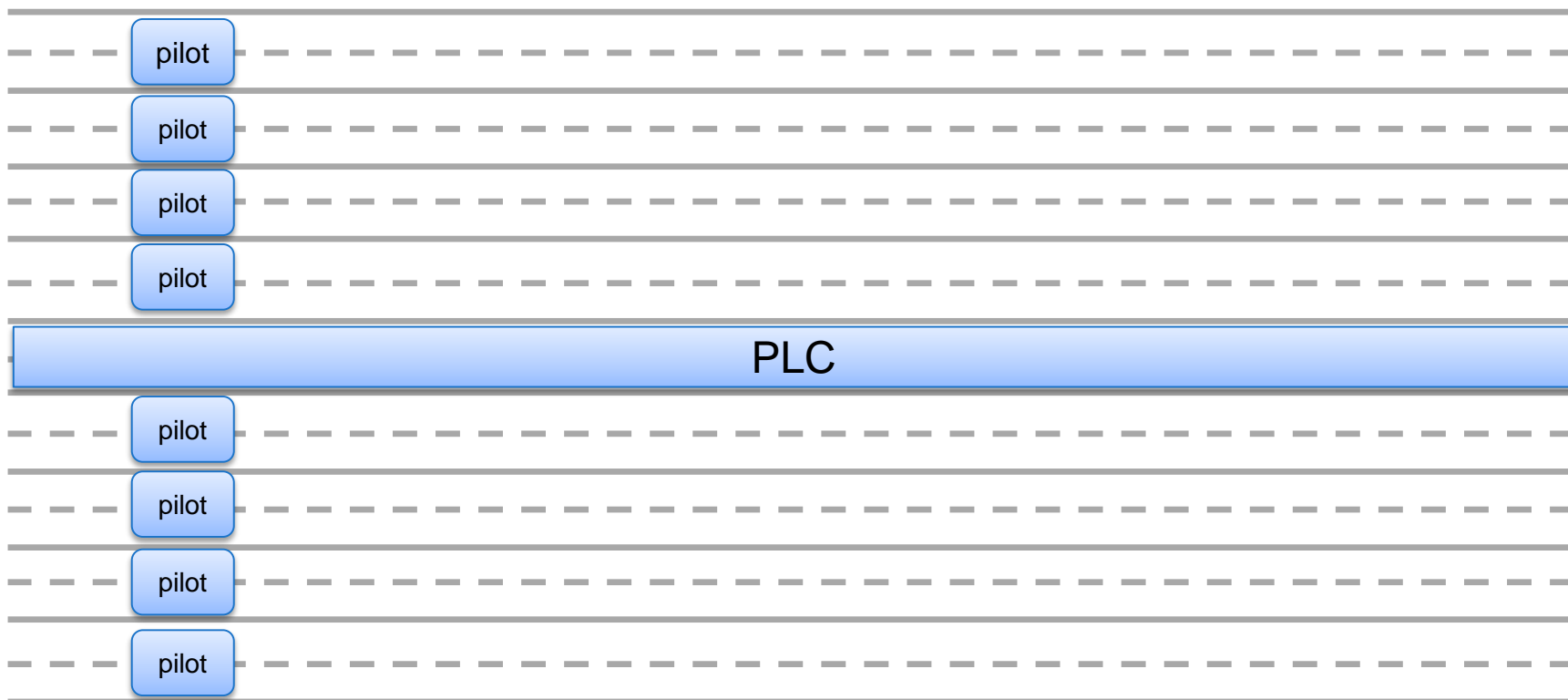

- There are 8 Continuous Pilots within the 6 MHz BW of the PLC to make it easy for the modems to find the PLC
- The CPs are used for receiver (cable modem) synchronization of frequency and phase.

Continuous Pilots

PLC Surrounded by
Continuous Pilots

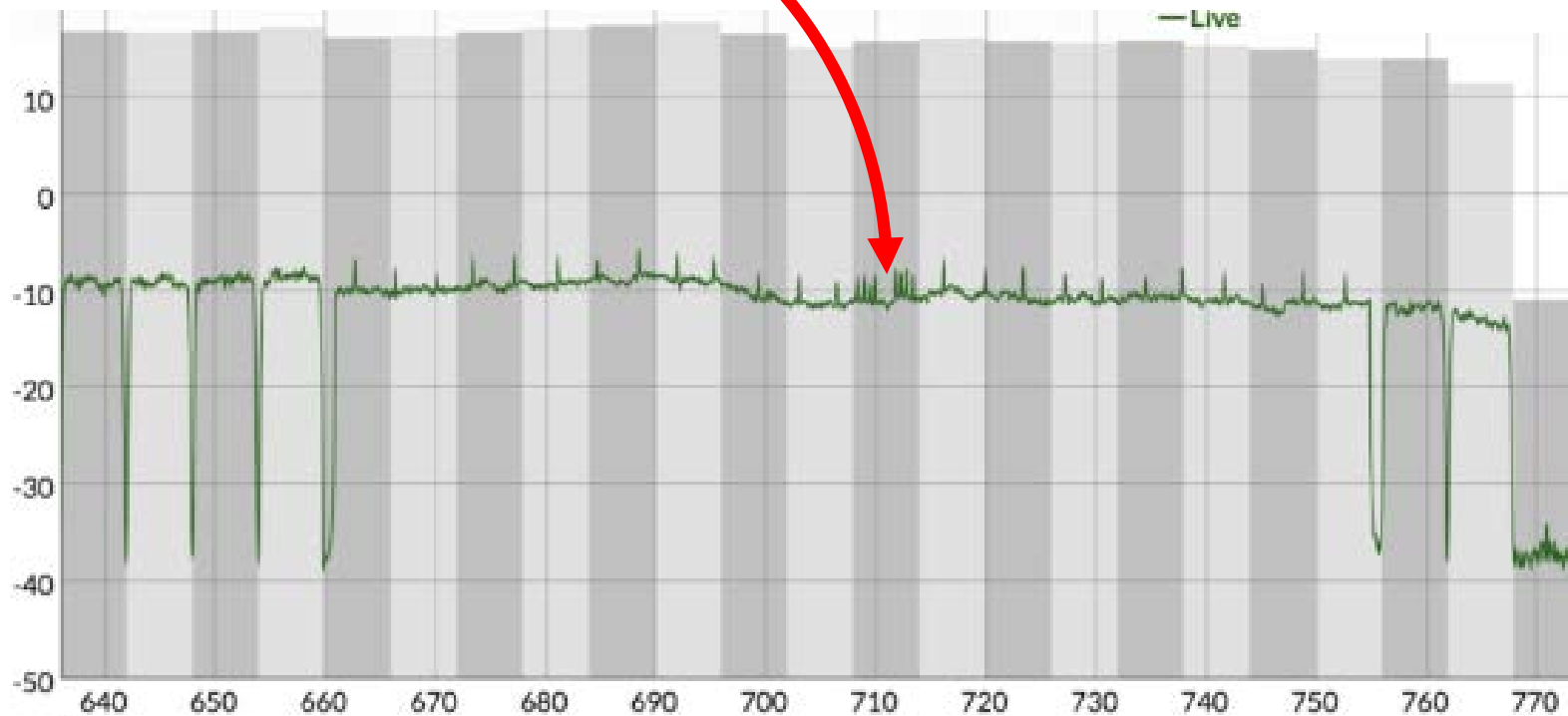

Scattered Pilots

- There are also Scattered Pilots spaced at every 128 sub carriers
- Pilots are staggered from one symbol to the next
- The modems use the scattered pilots estimate carrier performance (latency, attenuation, phase shifts)
- They are used to estimate frequency response for equalization
- They measure noise power and MER to determine level of QAM or Profile

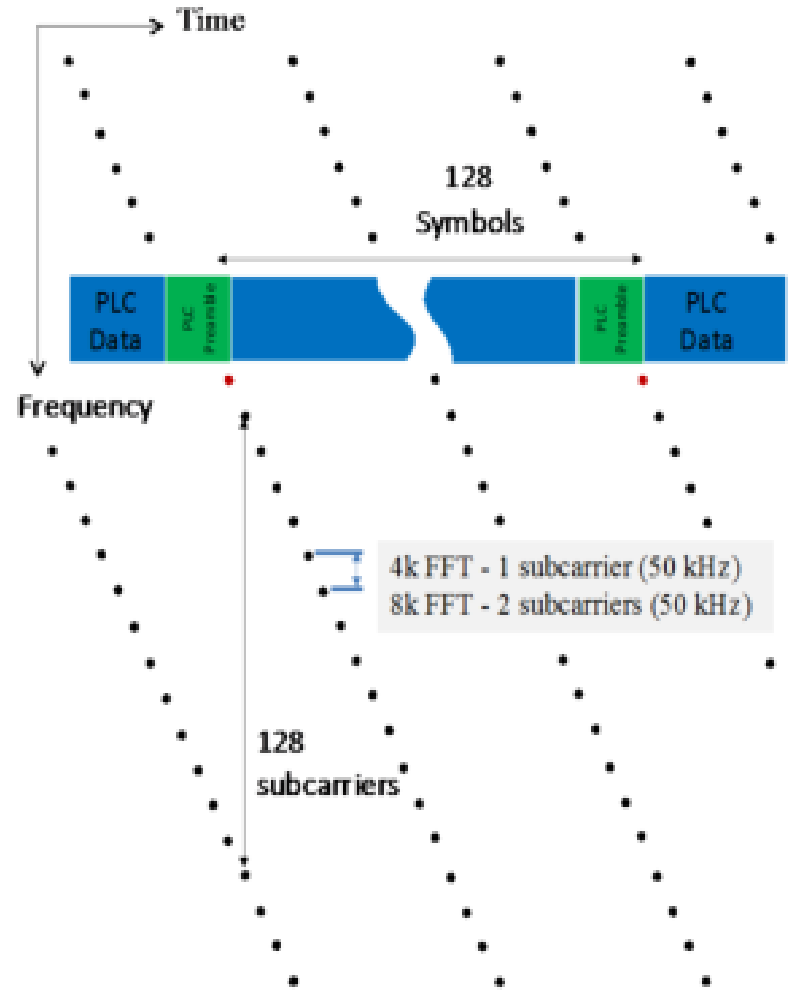

Cyclic Prefix

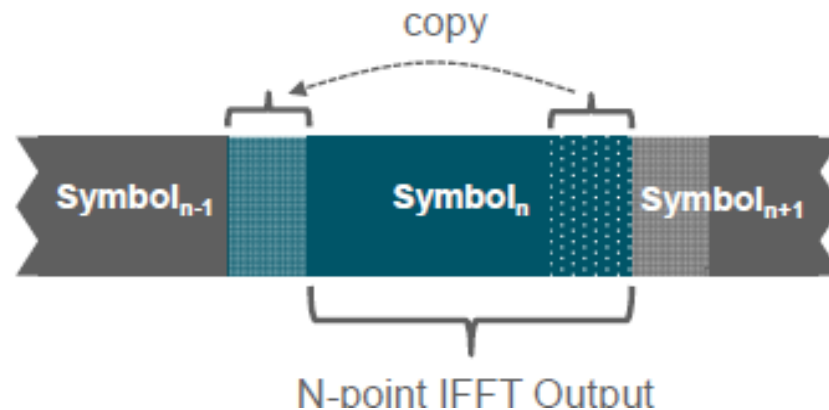

- The data from the end of each symbol is added to the time period of the beginning of the symbol.
- The time duration of the CP should longer than the time of the longest significant reflection.
- The CP does add overhead to the OFDM carriers

Cyclic Prefix- data from the end of the symbol added to the beginning

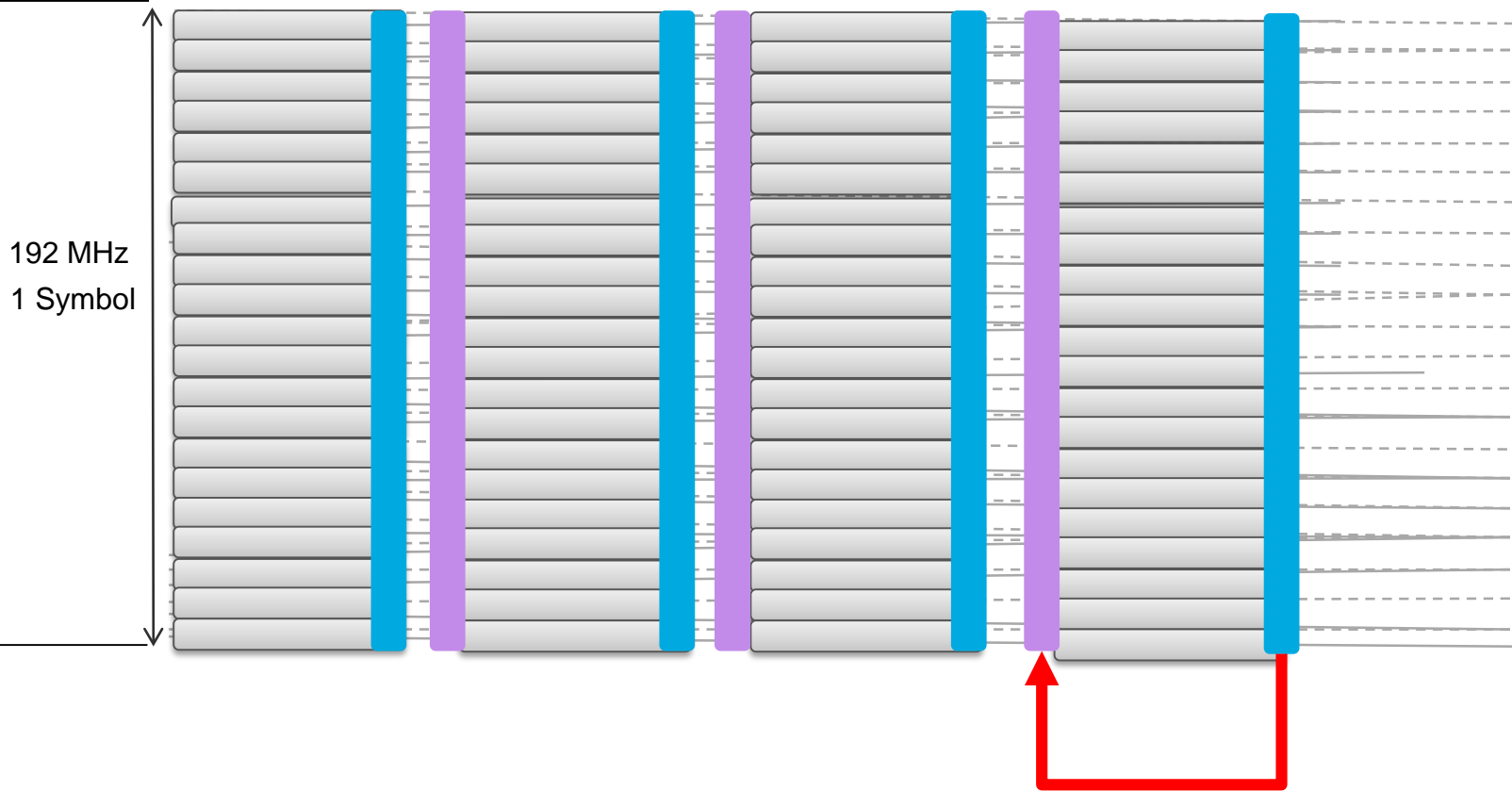

Cyclic Prefix prepended to time in between symbols

Windowing

- Simply put it is a raised cosine filter that determines how the carrier rolls off at the beginning and end of the carrier. Also at the beginning and end of exclusions
- The roll off must be integrated within the duration of the CP
- Windowing provides resilience against narrow band interference.

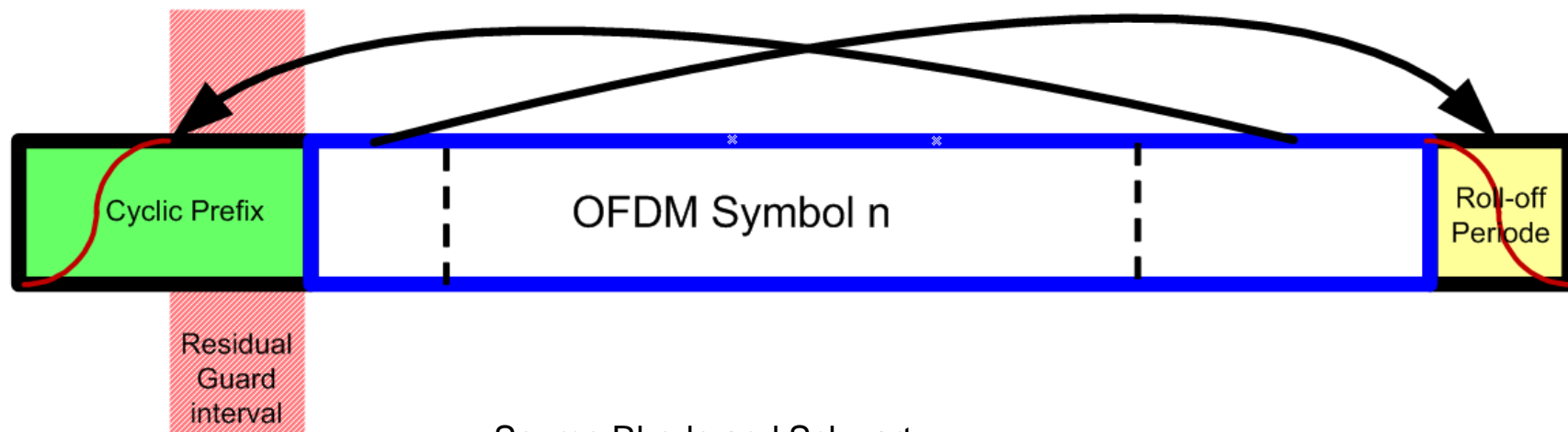

Source Rhode and Schwartz

Active Queue Management

- Increases operator's ability to improve customer's QoE by moving packets more efficiency.
- Boosts responsiveness for gamers and other web applications by reducing latency
- Actively manages data passing through the network and optimizes cable modem buffer usage.

OFDM and Adaptive Equalization

Another major advantage of OFDM is the ability to adapt to degraded conditions such as micro-reflections without the need for complex adaptive equalization.

OFDM uses a very narrow bandwidth subcarrier typically experiences what is known as “flat fading” when micro-reflections affect channel response.

This is in contrast to a 6 MHz wide QAM carrier and is susceptible to amplitude ripple (standing waves) across the entire bandwidth.

Each OFDM subcarrier “sees” a tiny portion of the ripple, that affects only the amplitude of the narrow subcarrier.

Since the subcarriers are so narrow, we can simply attenuate individual sub carriers accordingly as opposed to a complex AE

OFDM and Equalization

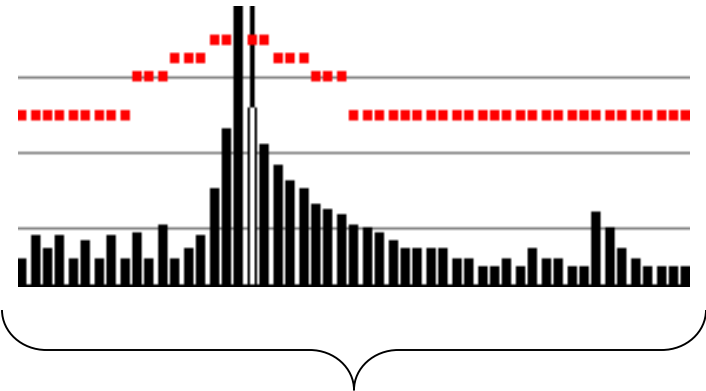

Complex single Adaptive EQ
For a 6 MHz wide carrier

Simple attenuators for each
25 KHz sub-carrier replace
complex wideband AEs

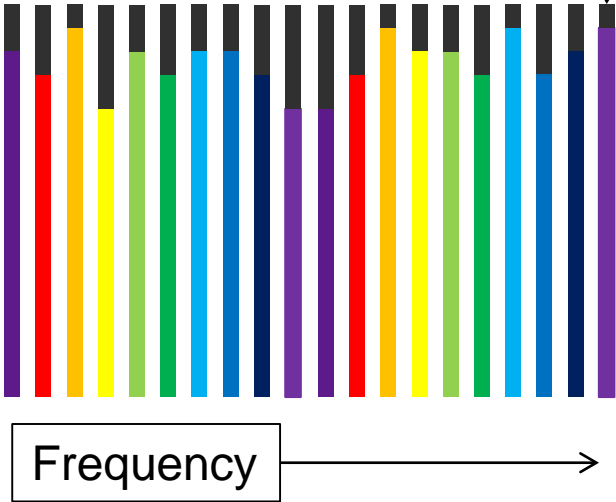

Time and Frequency Interleaving

- Frequency Interleaving minimizes the effects of narrowband interference
 - Errors are distributed over multiple sub carriers
 - Performed at sub carrier level
- Time Interleaving minimizes the effects of impulse noise
 - Errors on a single symbol are distributed on multiple OFDM symbols
 - Performed at the sub carrier level

Time Interleaving

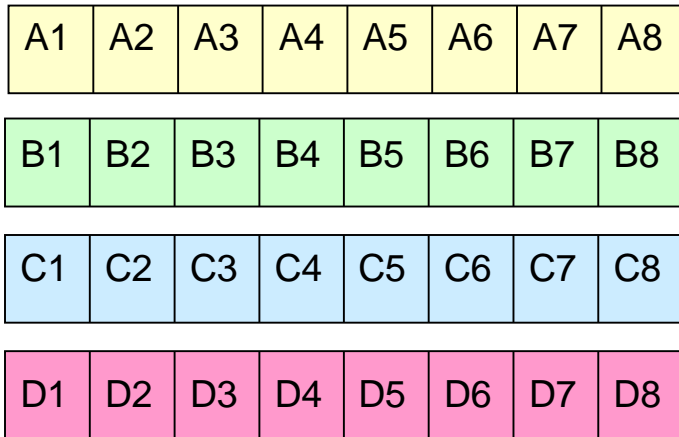

Non-Interleaved

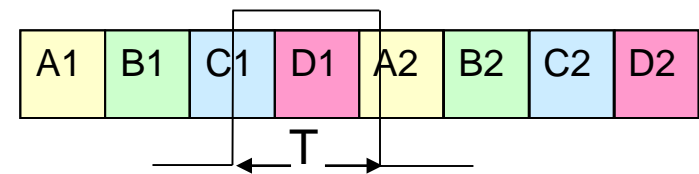
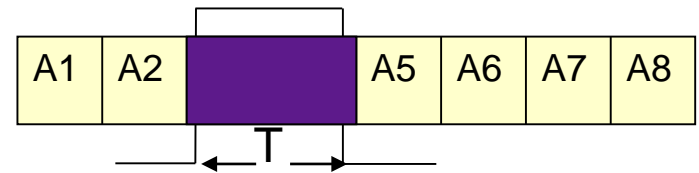

Interleaved

Time and Frequency Interleaving

Time Interleaving helps with wideband burst noise

Frequency interleaving helps with ingress and interfering carriers

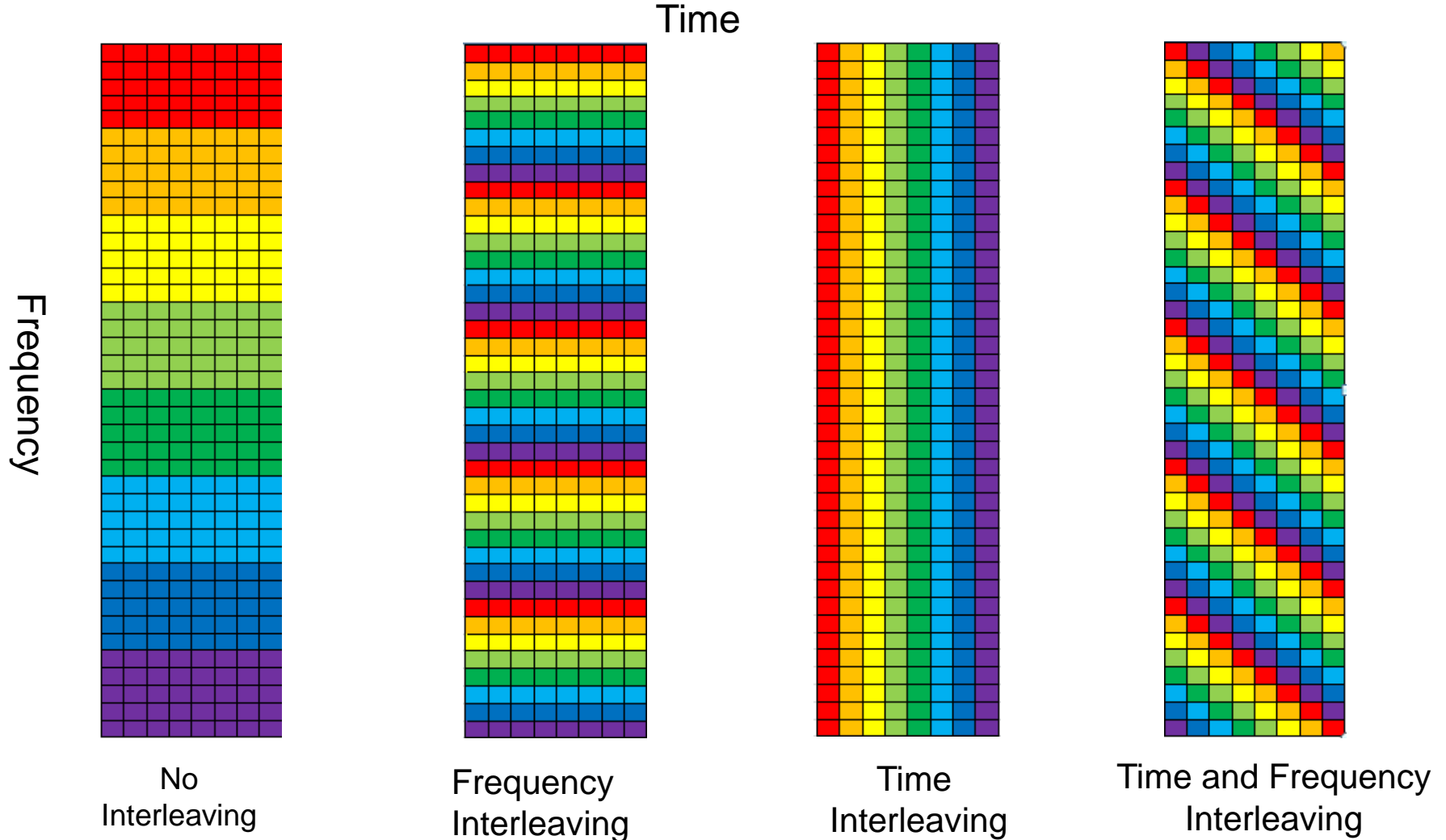

Downstream Conclusions

- OFDM Modulation
- System optimized for simplicity and efficiency
- Frequency agility allows for exclusions due to interferers and legacy channels
- Ideal modulation scheme that provides maximum data efficiency
- Multi-Profile architecture to match CM MER distribution
- Improved error correction, LPDC, provides higher orders of modulation with the same CNR

Upstream OFDMA

Upstream OFDMA Parameters

Parameter	Values
Subcarrier Spacing	50 kHz, 25 kHz
Useful Symbol Duration	20 μ s, 40 μ s
Cyclic Prefix Range	0.9375 μ s - 6.5 μ s
Min # of Tx Channels	2
Ch. Bandwidth Range	6.4 MHz - 96 MHz
Coding Rates	0.75, 0.85, 0.89
# of Subcarriers / 96 MHz	1920 (50 KHz), 3840 (25 KHz)
US Spectrum	5 MHz to 200 MHz
Modulation Order Range	BPSK to 4096-QAM

Upstream Carriers

- Remember that in the upstream the carriers will be wider than the normal 6 MHz bandwidth and that power levels will need to be modified to reflect the change in BW.

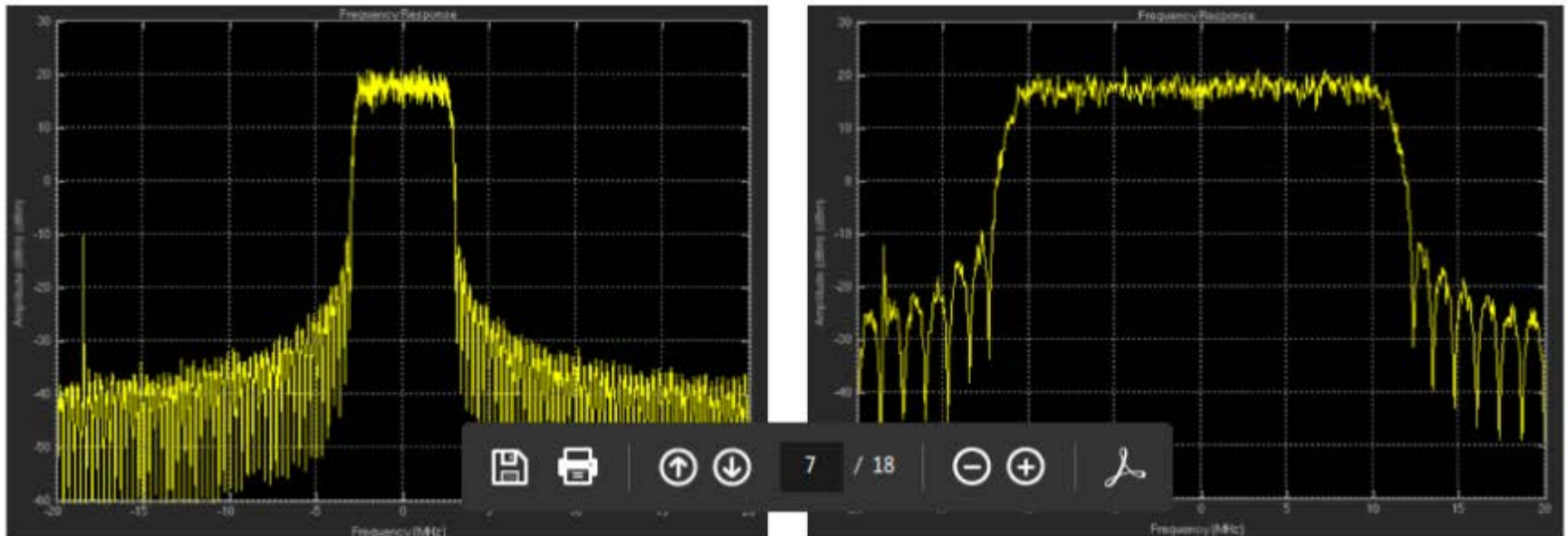

OFDM-A overlay in upstream

D3.0 and D3.1 Upstream Spectrum Sharing

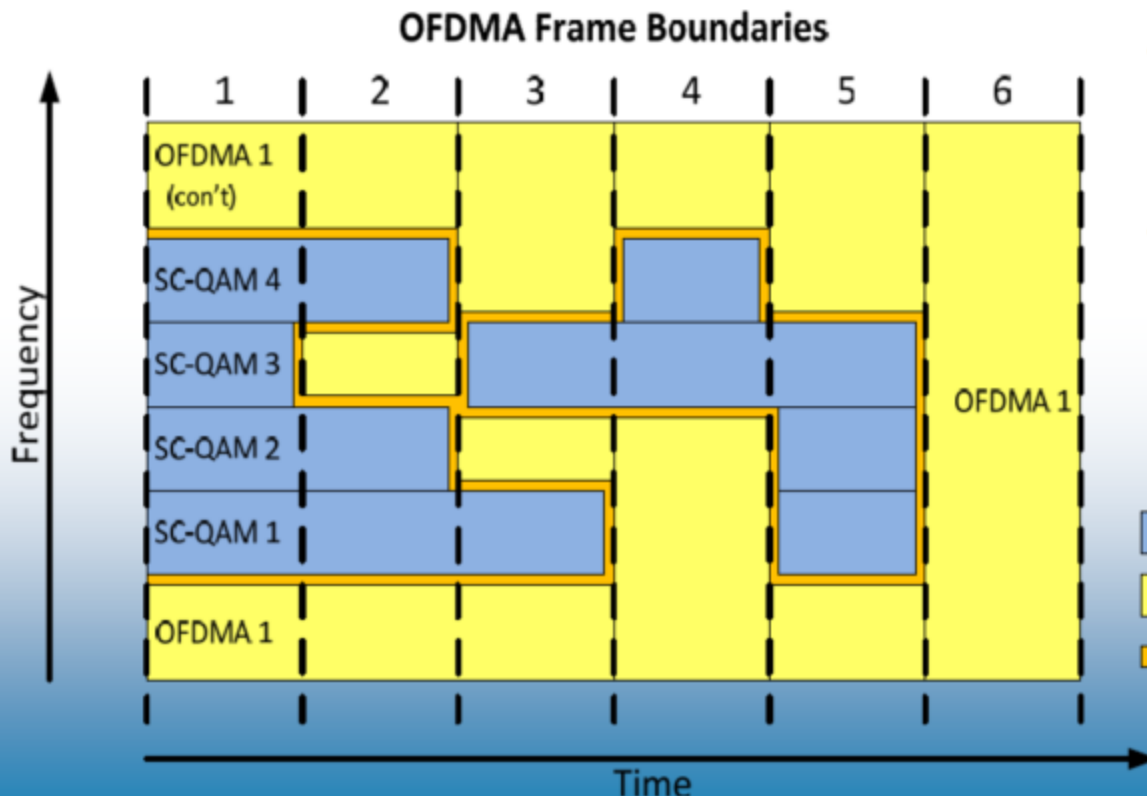

- SC-QAM and OFDM can also share the same frequencies.
- 1 MHz guard band needed between SC-QAM and OFDM channels.

- SC-QAM channels
- OFDMA channel
- Guard Band, unused

Source: Cisco, John Chapman, CED DOCSIS 3.1 webinar 11/2013

OFDM-A – Frames and MiniSlots

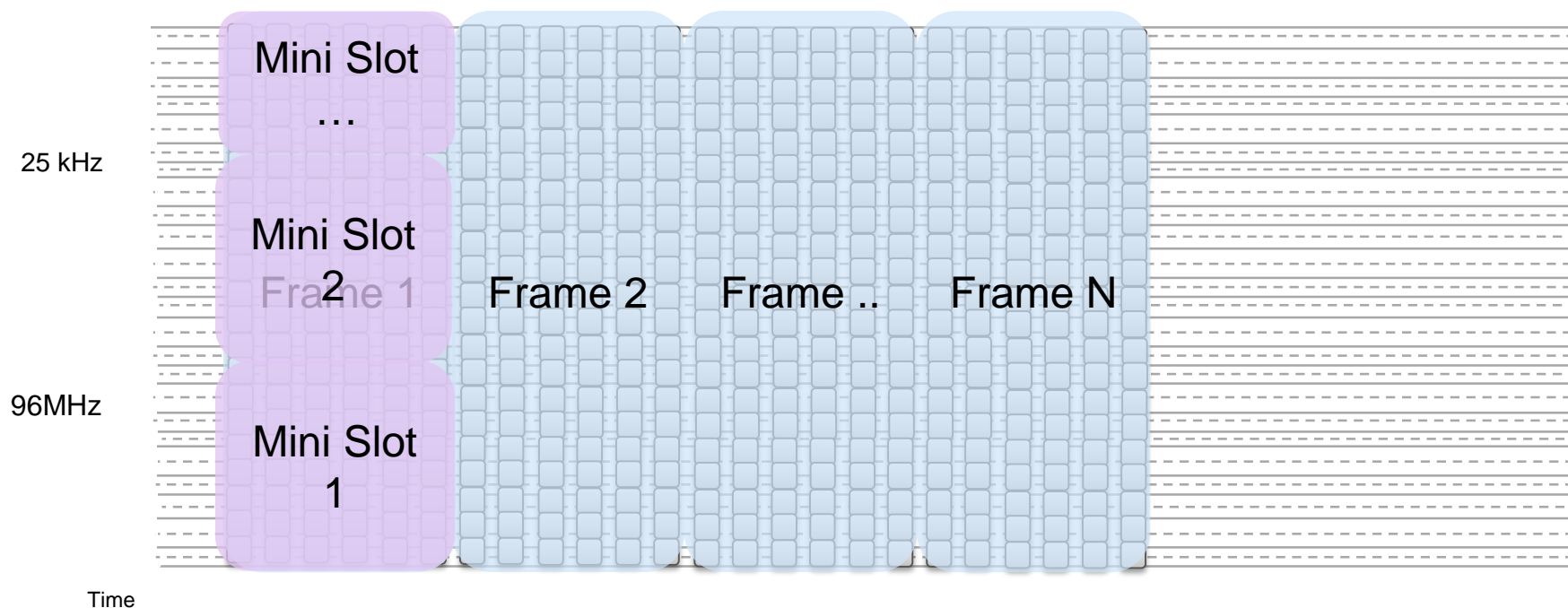

- Symbols are grouped into frames – configurable from 6-32 symbols
- Subcarriers are grouped into mini-slots
 - Must be either 8 or 16 subcarriers per mini-slot
 - Subcarriers can be bit-loaded from QPSK to 4096 QAM

OFDM-A – Exclusions and Unused

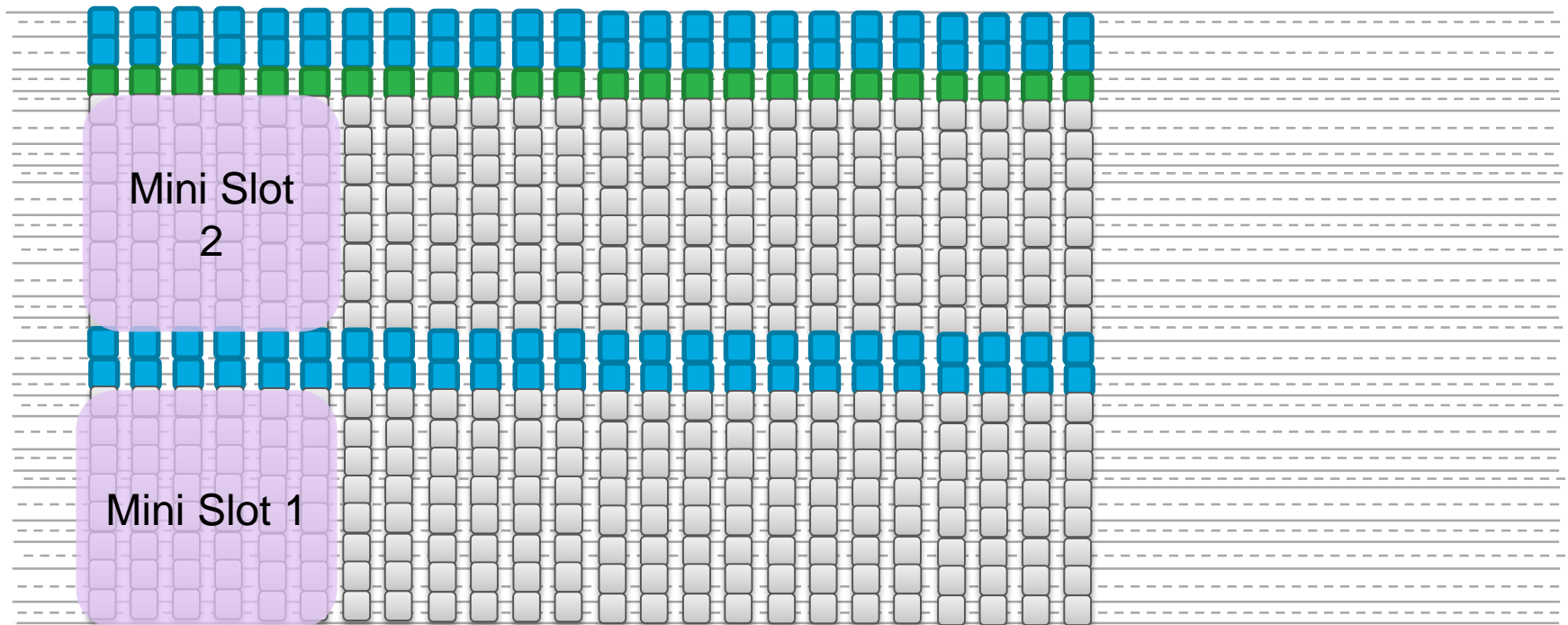

- Excluded frequencies occur between mini-slots.
- Unused frequencies may be defined and occur between mini-slots.
 - Unused carriers are used for pilot transmit probes for PNM

Upstream Multiple Modulation Profiles

- Different modems have different MERs at the CMTS
- In D3, the modem with the lowest MER normally dictates the highest level of upstream QAM or the highest speed capability
- D3.1 will provide multiple modulation profiles so that each modem will be able to transmit at it's highest QAM modulation profile
- Profiles are assigned at registration
- Profiles can be dynamically changed using UCD change procedure
- Operators can tailor profiles to meet plant conditions
 - Profiles are not unique to each modem

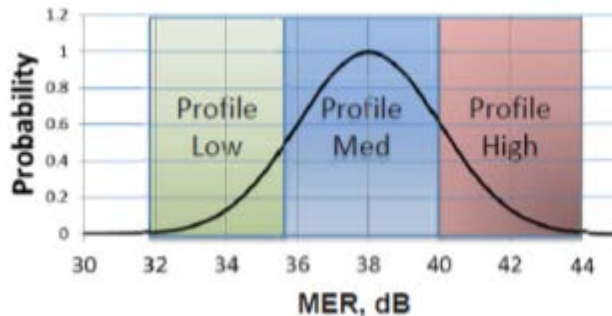

A typical Normal distributed MER profile of a set of CMs

Upstream Pilots

- Upstream Pilots are subcarriers that do not carry data.
- Instead a pilot subcarrier encodes a pre-defined BPSK symbol known to the CMTS.
- Pilots are used by the CMTS receiver to adapt to channel conditions and frequency offsets.
- Complementary pilots are subcarriers that carry data, but with a lower modulation order than other data subcarriers.
- The CMTS may use the complementary pilots to enhance its processing and accuracy

Upstream Pre Equalization

- One equalization coefficient per sub-carrier
- CMTS evaluates and determines EQ adjustments
- CMTS sends EQ adjustments to the cable modem
- Increases the accuracy of PNM distance measurements from several feet to a few inches.

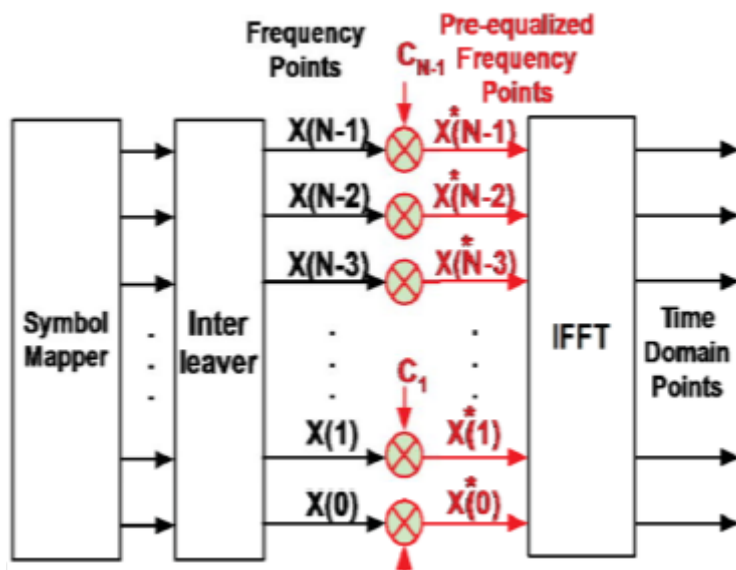

Upstream Conclusions

- OFDMA is:
 - Robust:
 - Profiles fit system performance
 - Interleaving
 - LPDC
 - Minislots and Framing
 - Flexible
 - Different levels of QAM and bonding
 - Works with legacy upstreams
 - Exclusions
 - Transmits at the same frequencies as legacy carriers during time periods when they aren't being used.
 - Up to 2 96 MHz wide carriers with up to 200MHz upstream bandwidth

Testing what matters in D3.1

DOCSIS 3.0 Testing at the CM and CMTS

- CMs and CMTSs were not designed to be test equipment but we did get.....
 - Spectrum Analysis at both the CM and CMTS
 - Pre EQ coefficients that aid in troubleshooting (PNM tools)
- In D 3.1 measurements from the CMTS and CMs are specified.

DOCSIS 3.1 Testing

- In 3.1, CMs and CMTSs are specified to act as test equipment
- Adds:
 - NPR testing on the downstream and upstream. (Like IUC)
 - Visibility of LTE
 - Intermodulation Products
 - Downstream Ingress
 - Constellation and MER measurements
 - Increased accuracy of Pre EQ taps
 - Taps go from 400 KHz to 50 KHz increasing the accuracy of PNM calculated distances by 8 times.
 - Upstream and Downstream Channel Estimates
 - The CMTS and CM remember every symbol it transmits
 - The transmitted symbols can then be compared to what is received and a sweep trace can be produced.

Remote PNM Diagnostic Tool

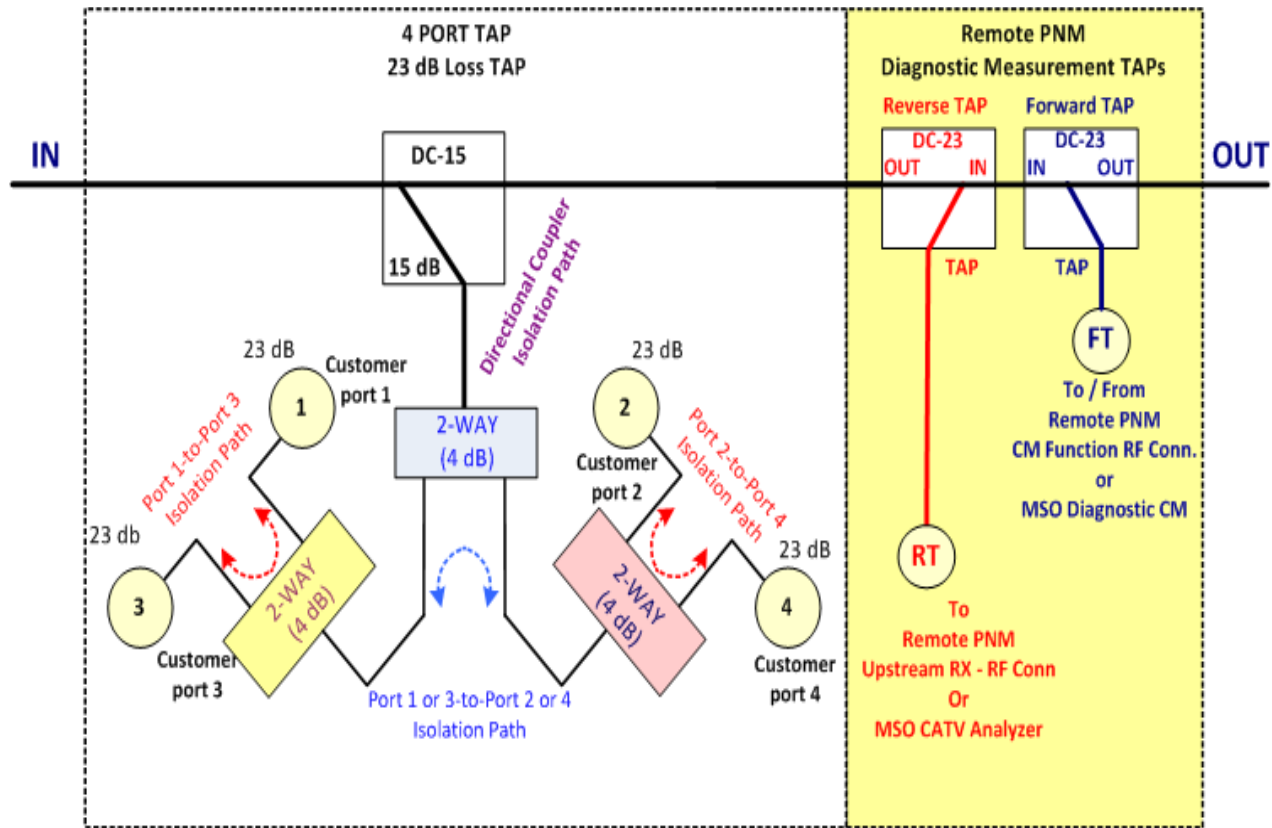

Please note that in this example, the existing four-port tap faceplate displayed in the white area is replaced by a new faceplate that has the existing tap structure in white but also the new forward and reverse test taps as displayed in the yellow area. Spliced in each leg of a node or within the housing itself.

Source: Jack Moran

Modem Pre EQ Proactive Network Maintenance



- PNM Identifies modems with poor upstream performance and separates modems with different issues.

Downstream Spectrum Analysis at the Cable Modem



Downstream Spectrum Anomalies at the Cable Modem

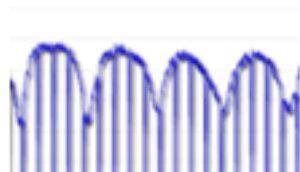

Standing Waves

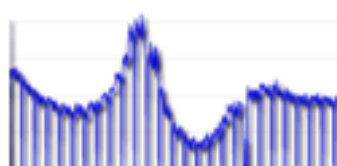

Resonant Peaking



4G LTE Ingress

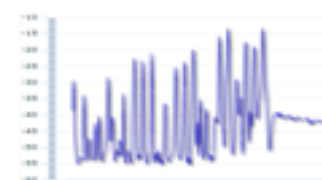

FM Radio Ingress



RF Notches

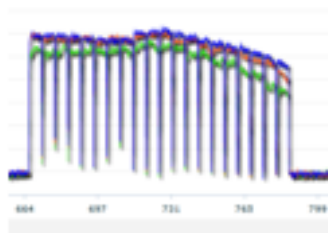

Roll-off

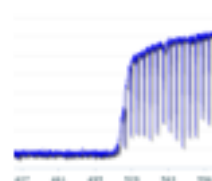

Filters

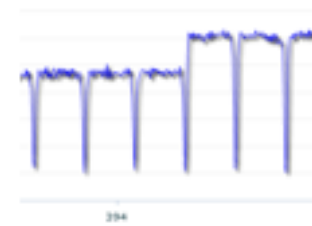

Adjacency

Symbol Capture

Ordinary OFDM symbol is captured by CMTS at input to cable plant

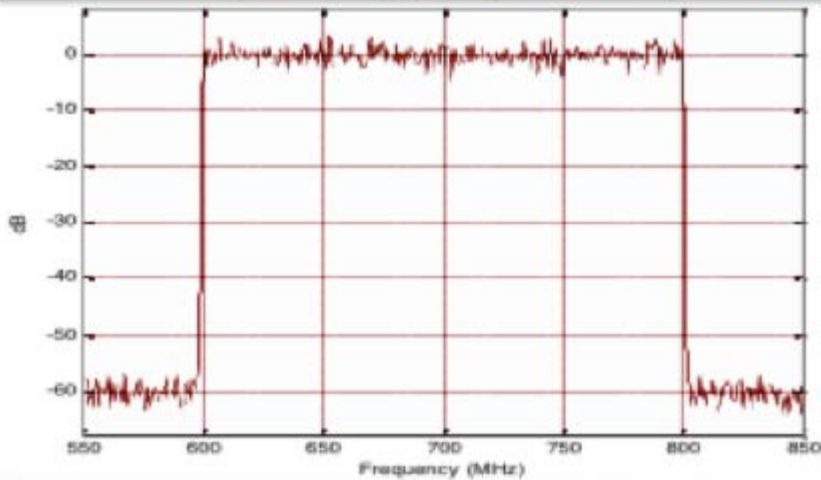

The same received symbol is captured by CM after cable plant

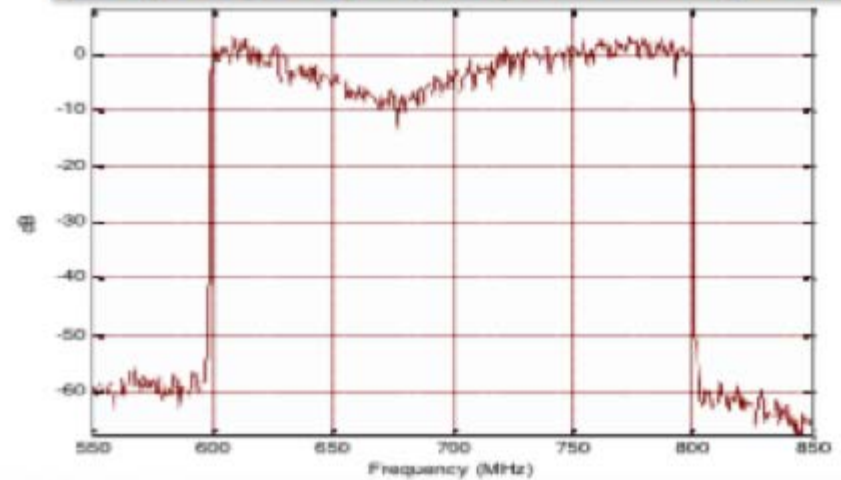

Source: Broadcom

Notch Filter Testing at the CMTS (NPR)

Notch spectrum after passing through clean plant

Spectrum of OFDM probe signal after channel

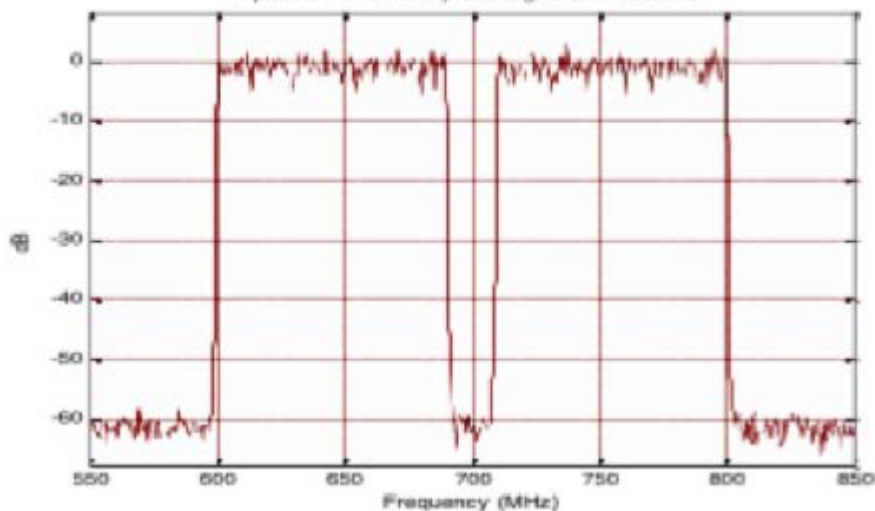

Notch after 3rd order nonlinearity

Spectrum of OFDM probe signal after channel

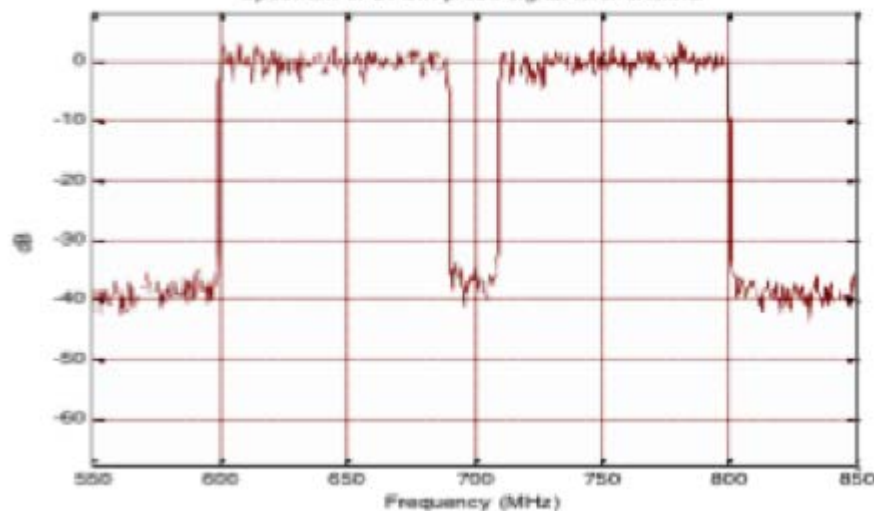

Uses Exclusion Bands to test for upstream dynamic range

Important D3.1 Field Measurements

- Downstream
 - Physical Layer
 - Power Levels of the carrier
 - MER across the carrier
 - Noise Profiles under the carrier
 - PLC
 - Channel Lock
 - Codeword Errors
 - NCP
 - Channel Lock
 - Codeword Errors
 - Profiles
 - Profile A: Lock and Codeword Errors
 - Every modem needs to receive Profile A so there should be no uncorrectable CWE
 - Other Profiles: Lock and Codeword Errors
 - The higher performance tiers will want to run on better profiles

What is important to test and measure on DOCSIS 3.1

- Service Layer
 - Registration and Bonding
 - Did it register and come on line as 3.1?
 - Are the 3.1 OFDM carriers active and bonded?
 - Upstream
 - Carrier Power levels
 - Bonding – Am I getting the bonding I expected
 - ICFR – In Channel Frequency Response of each carrier

Testing the OFDM Building Blocks

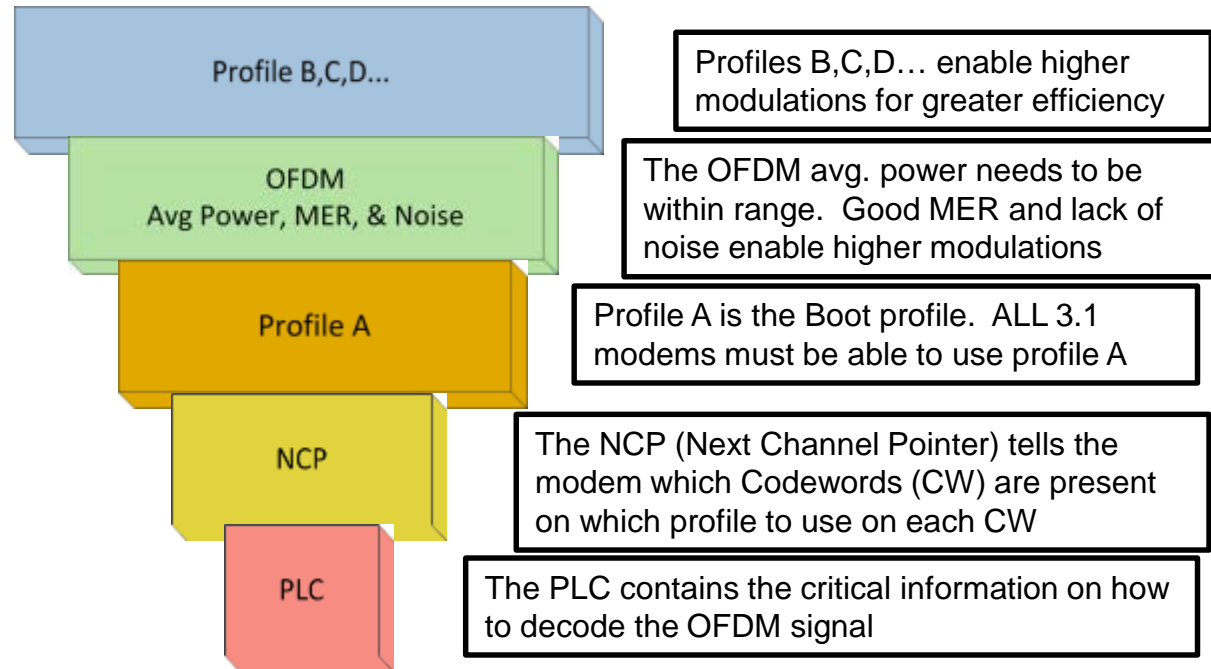
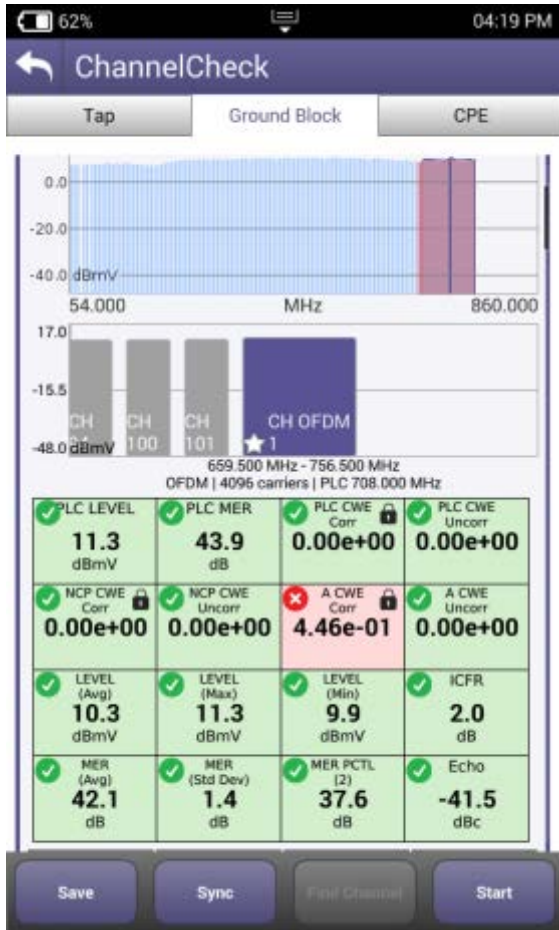

DOCSIS Codewords

- In our example, each code word consists of 128 RS symbols. 122 of those symbols carry data. The remaining 6 symbols are used for error correction.
 - ITU-T J.83, Annex B* states that the data is “...encoded using a (128,122) code over GF(128)...” which shows each RS codeword consists of 128 RS symbols (first number in first parentheses) and the number of data symbols per RS codeword is 122 (second number in first parentheses), leaving six symbols per RS codeword for error correction.
- DOCSIS RS FEC is configured for what is known as “ $t = 3$,” which means that the 6 FEC can fix up to any three errored RS symbols in a RS codeword.

DOCSIS Downstream Codewords

- In DOCSIS Reed Solomon FEC, 7 bits = 1 RS symbol, and 128 RS symbols = 1 RS codeword

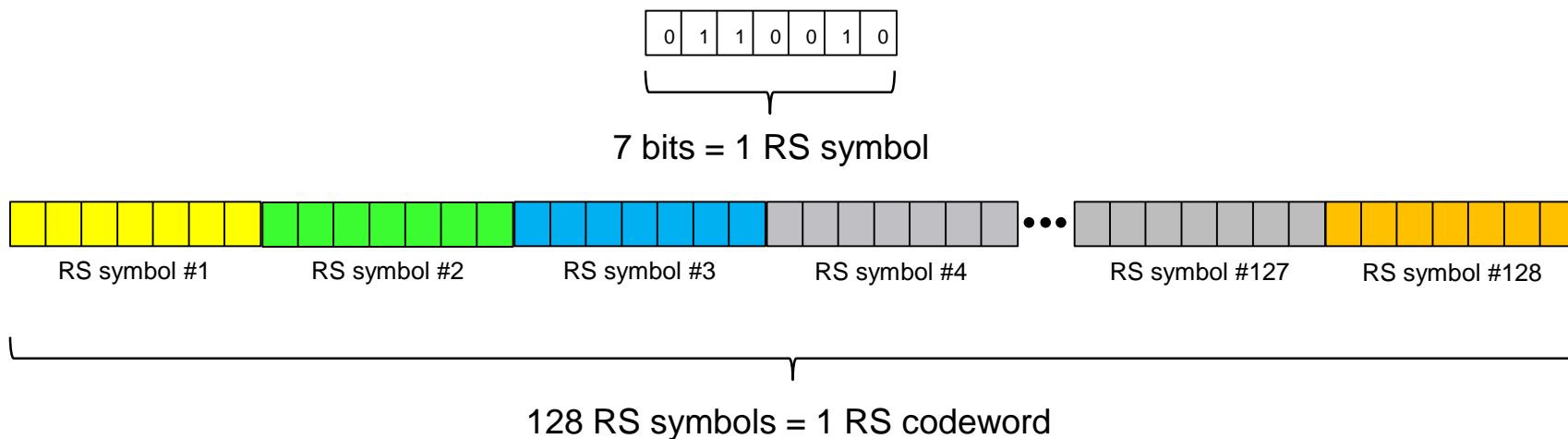

In each RS codeword: 122 RS symbols = data symbols, 6 RS symbols = parity symbols

Source Ron Hranac

Codeword Errors

- What happens when there is, say, a burst of noise that causes a bit error or errors in one RS symbol?
- It doesn't matter to the RS decoder if one bit in that RS symbol is errored or all seven bits are errored—the entire symbol is considered broken.



Source Ron Hranac

Codeword Errors

- With a RS FEC configuration of “ $t = 3$ ” the FEC decoder can fix up to any 3 errored symbols in a RS codeword

128 RS symbols = 1 RS codeword

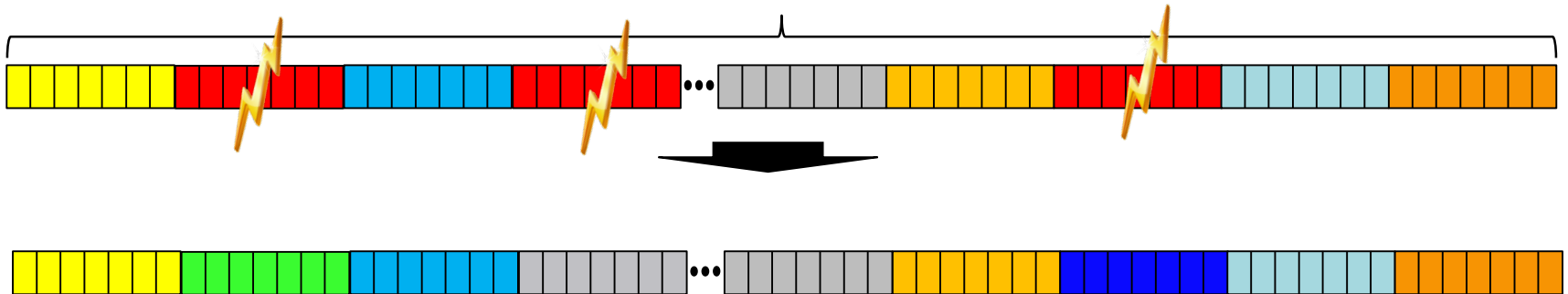

This is a correctable codeword error

- When there are **more** than 3 errored symbols in a codeword the **entire**

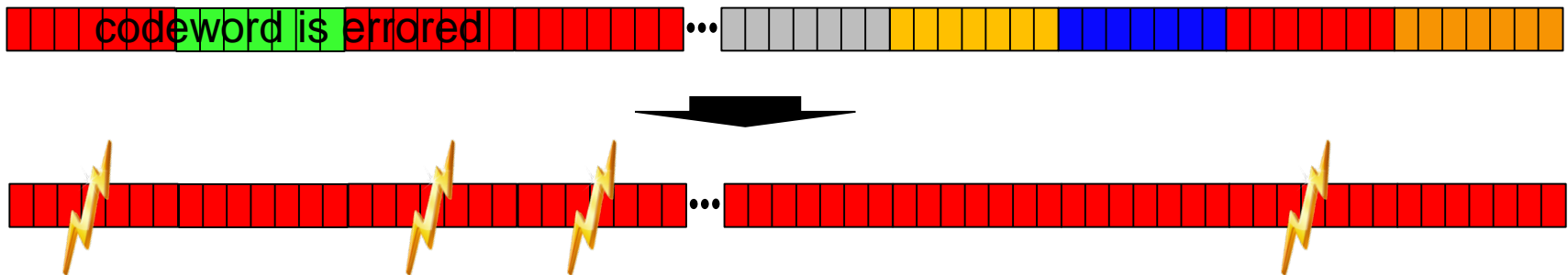

This is an uncorrectable codeword error

Testing the OFDM Building Blocks

PLC – Phy Link Channel



PLC

The PLC contains the CRITICAL information on how to decode the OFDM signal

Things to Check:

- Uncorrectable CWE: NONE
- Lock Status: Locked
- MER: > 15dB (min)
- Level: > -15dBmV (6MHz)
- Other info: PLC Center Freq

Testing the OFDM Building Blocks

Next Codeword Pointer



The NCP (Next Channel Pointer) tells the modem where Codewords (CW) start and which profile to use on each CW

They are CRITICAL for proper data communication

NCP

Things to Check:
Uncorrectable CWE: NONE
Lock Status: Locked

Testing the OFDM Building Blocks Profile A

Profile is the cornerstone for a D3.1 modem to actually operate on the OFDM carrier. This is where the command and control, range and registration occurs.

In practice Profile A may be assigned lower mixed modulations like QAM 64/16 so every 3.1 modem can communicate. Lower modulation profiles can operate at lower MER/CNR and power levels.

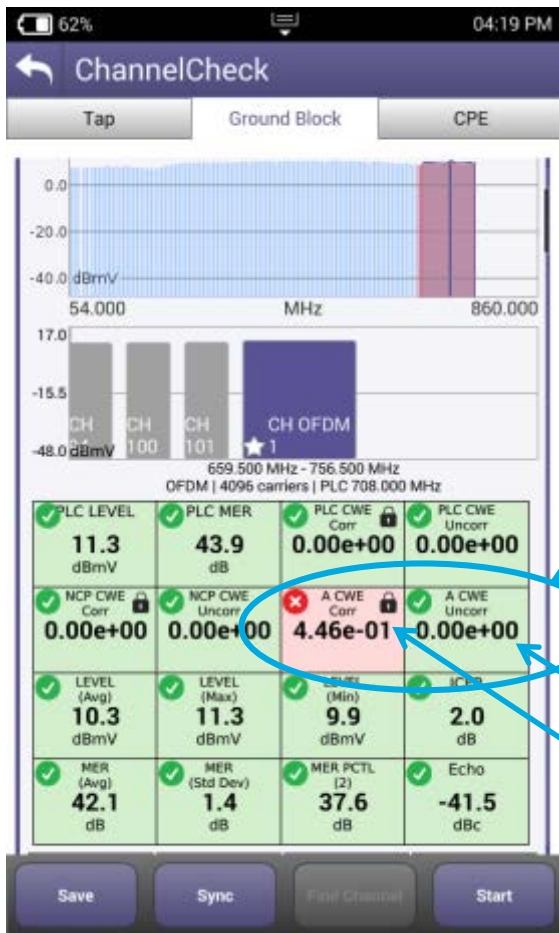

Profile A

Profile A is the Boot profile. ALL 3.1 modems must be able to use profile A

Things to Check:
 Uncorrectable CWE: NONE
 Lock Status: Locked

If Profile A isn't locked or has Uncorrectable. CWE the modem may roll back and use only SC-QAM's in 3.0 mode

How to set the level of a D3.1 OFDM carrier

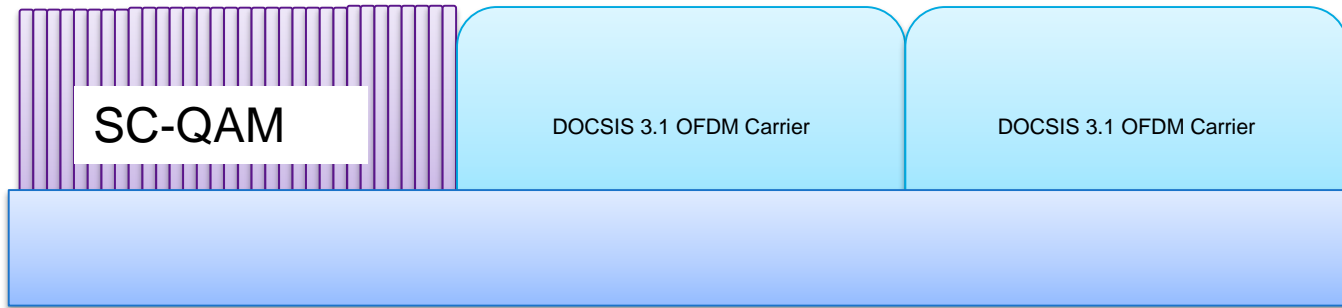

DOCSIS 3.1 OFDM carrier power levels should be measured and referenced in comparison to the power in a 6MHz carrier.

In a flat system, the average power of the OFDM, referenced to a 6MHz carrier should be set to the same power level as the adjacent QAM 256 carriers.

NOTE: The TOTAL power of the OFDM carrier is greatly different than the average power in a 6MHz bandwidth.

Total Power = Total Power PER Channel (6MHz) + $10\log_{10}(\text{Channel Bandwidth})$.

Where Channel Bandwidth would be overall OFDM Bandwidth/6MHz channel bandwidth = # of 6MHz Channels
for a 96MHz wide OFDM carrier the TOTAL power will be 12.04dB higher
for a 192 MHz wide OFDM carrier the TOTAL power will be 15.05dB higher

NOTE: DON'T USE THE TOTAL OFDM POWER to ADJUST CMTS OUTPUT POWER
(This would be like using the total integrated power of 32 DOCSIS QAM carriers to set the level)

Single 6MHz channel power = 5 dBmV

Total Power(96MHz channel) = $5\text{dBmV} + 10\log_{10}(16) = 5 + 12.04 = 17.04\text{dBmV}$

This is what some spectrum analyzers (like R&S FSW) show –

total power of 96MHz wide carrier: This is not referenced to a 6MHz carrier

Measuring Channel Power

- Using a OneExpert CATV (ONX-620) to set power levels

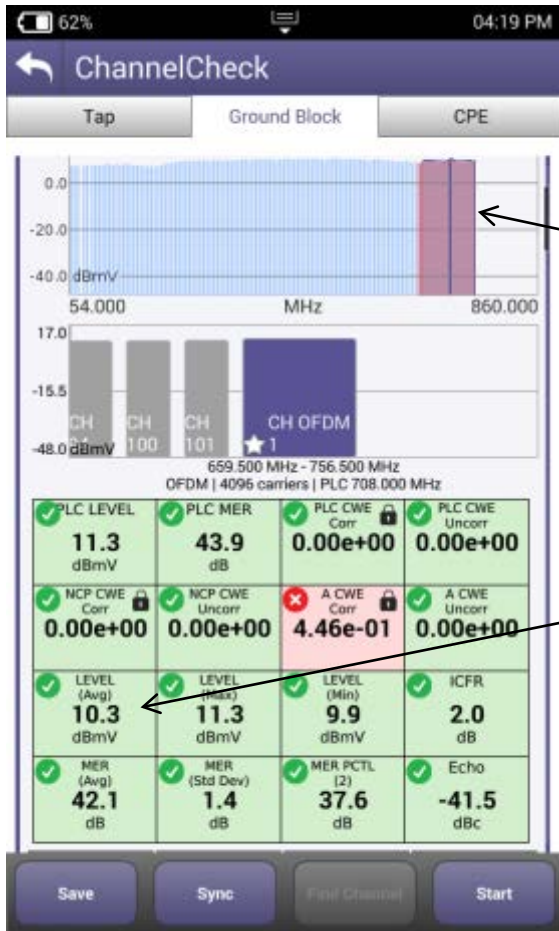

Select the OFDM carrier in the cover flow

Look at the average Level of the OFDM Carrier

The Level should be set similar to the power of the 6MHz SC-QAM's eg. All at 10dBmV

Channel	Freq (MHz)	Level (dBmV)	MER (dB)
93	639.000	9.7	44.5
94	645.000	9.1	44.1
100	651.000	9.2	44.1
101	657.000	9.4	37.6
OFDM 1	708.000	10.3	42.1

Testing the OFDM Building Blocks

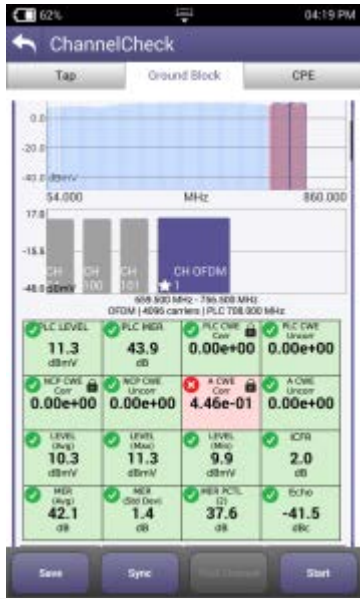

Profile B,C,D...

Profiles B,C,D... enable higher modulations for greater efficiency



	TAP		Ground Block		Outlet/CPE	
	Profile Locked?	Uncorrectable CWE	Profile Locked?	Uncorrectable CWE	Profile Locked	Uncorrectable CWE
Profile A	YES	NO	YES	NO	YES	NO
Profile B	YES	NO	YES	NO	NO	YES
Profile C	YES	NO	YES	YES	NO	YES
Profile D	YES	NO	NO	YES	NO	YES

PROFILE ANALYSIS

PROFILE	LOCKED	CWE (Corr)	CWE (Uncorr)
A	YES	3.36e-02	0.00e+00
B	YES	1.00e+00	0.00e+00
C	NO	--	--
NSP	YES	0.00e+00	0.00e+00
PLC	YES	0.00e+00	0.00e+00

Profile changes highlight problems in drop and or home wiring:

Things to Check:
 Uncorrectable CWE: Varies
 Lock Status: Locked

Higher profiles makes the network more efficient. It is desirable to get as many modems running on higher profiles for overall network efficiency and customer quality of experience

Testing the OFDM Building Blocks

CodeWord Error Expectations and Impact

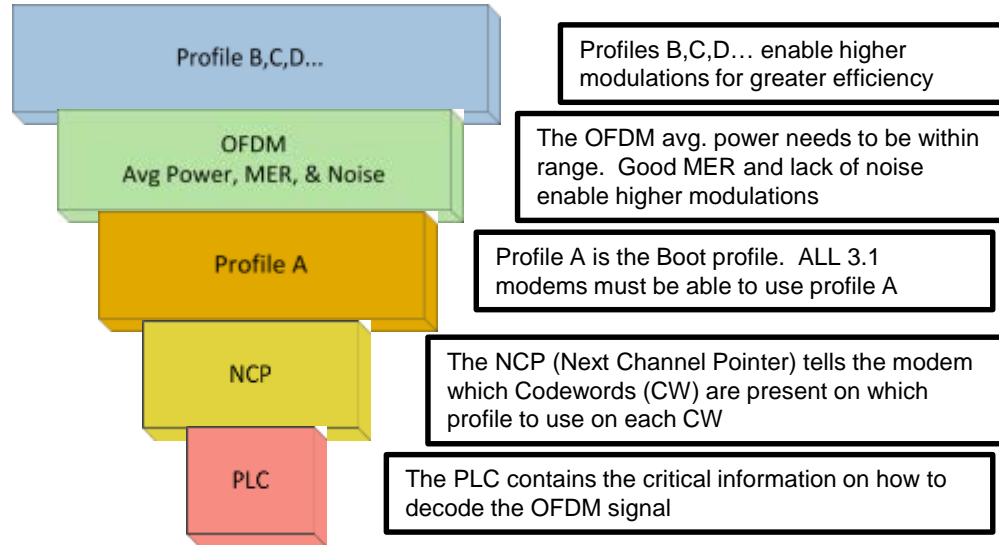

Component	Importance	Code Word Error expectations and impact
PLC	Critical	Should have 0 Uncorrectable CWE otherwise OFDM may not work
NCP	Critical	Should have 0 Uncorrectable CWE otherwise OFDM may not work
Profile A	Critical	Uncorrectable CWE will cause poor QOE and possibly make the OFDM carrier unusable forcing data to regular QAM carriers instead of OFDM
Profile B,C,D	High	Uncorrectable CWE will affect bandwidth and overall QOE

Service Testing

DOCSIS 3.1 Range, Register and BONDING

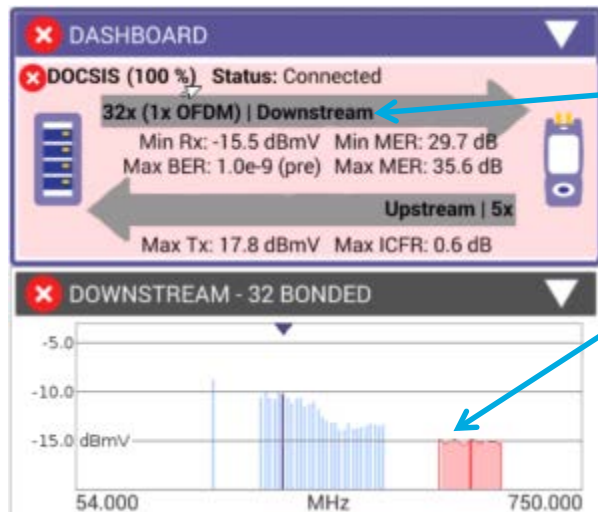

Things to Check:
Channel Bonding with OFDM
Upstream Bonding

Since a D3.1 modem is backward compatible, it can utilize just the 3.0 QAM carriers. By ensuring that the service is bonding with the OFDM carriers or using the OFDM carriers it validates that the high data customer will be working on the more efficient OFDM carriers and not impacting other customers.

DOCSIS 3.1 Testing

Signal Testing and Troubleshooting

Signal Testing

Looking at the MER across the entire list of subcarriers is important in order to identify potential impairments that affect the ability to carry higher level profiles

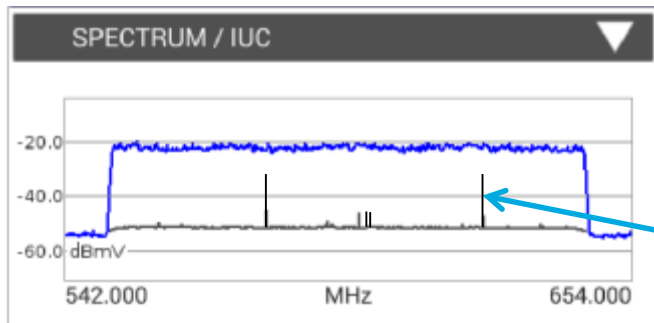

In-Channel Response identifies roll-off and excessive ripple



Unstable MER with drops below 30 means only the lower profiles running 256 QAM or lower will work

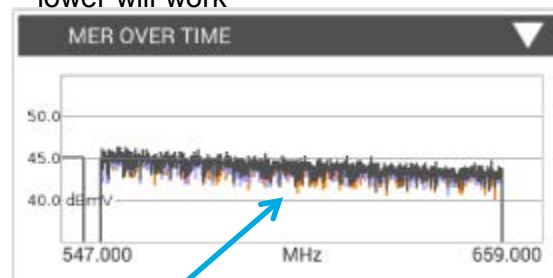

Stable MER better than 40dB means QAM 2048 and 4096 will work

Spectrum and Noise identify portions of the carrier where degradation may occur
Profiles may need to adjust for this

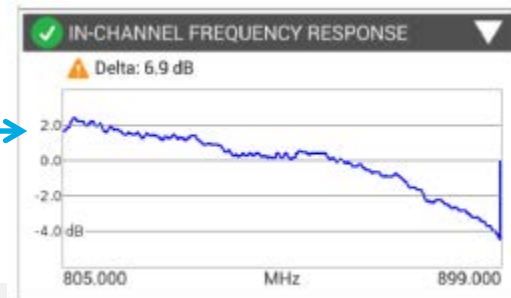

Service Testing Throughput

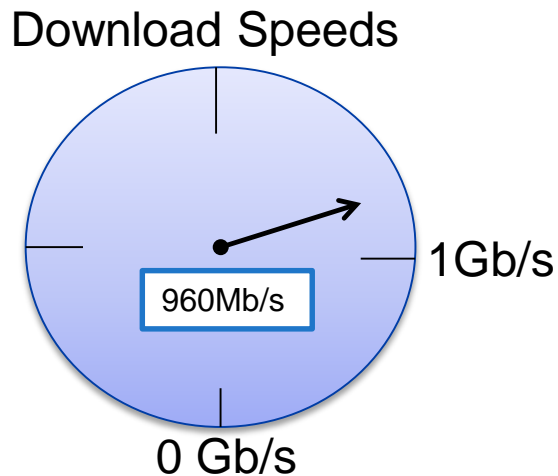

DOCSIS 3.1 systems can provide 1Gb/s or greater.

Validating that the network and service can operate at the subscribed rates is important to verify customer experience.

Testing at the DOCSIS service layer identifies RF impacts on the overall performance

Being able to test both DOCSIS service and Ethernet helps ensure customers' QOE.

Many consumer grade PC's have hardware limitations that prevent them from testing up to 1Gb/s. Having a test device that can test both the DOCSIS layer and Ethernet Layer to 1Gb/s helps distinguish between service problems or equipment problems.

3.1 testing summary

- PLC and NCP have to be locked and have no uncorrectable codeword errors before CMTS and modems can communicate
- Profile A must also be locked and have no uncorrectable codeword errors as the CM uses Profile A to range and register with the CMTS
- Power levels need to be equated to SC QAM carriers in a 6 MHz bandwidth
- Profiles can be checked between location
- Look for bonding with legacy DOCSIS carriers
- Check for ICFR and variations in MER
- Throughput



VI.VI

Thank You
Questions?

References

- “What is OFDM?”, Ron Hranac. Communications Technologies, Nov 2012,
• <http://www.scte.org/TechnicalColumns/12-11-30%20what%20is%20ofdm.pdf>
- “Modern Modulation and Multiplexing,” Daniel Howard, CTO SCTE.
- SCTE Live Learning Archives
- <http://www.scte.org/TechnicalColumns/12-11-30%20what%20is%20ofdm.pdf>
- “DOCSIS 3.1 Plans and Strategies,” Patricio Latino, Cable Consultant,
- SCTE Live Learning Webinar 12/18/13
- “Compatibility and Interference Issues on Migration to Mid-Split and High-Split,”
- Alberto Campos and Tom Williams, CableLabs, Presented at SCTE Tech Expo 2012
- “DOCSIS 3.1 Overview,” Ahyam Al-Banna, Ph.D, Staff Systems Architect, Arris
- “Testing in 3.1,” Brady Volpe, The Volpe Firm, Broadband Library
- “DOCSIS 3.1 Pocket Guide,” CableLabs
- “DOCSIS 3.1 App Note”, Rhode and Schwartz, http://cdn.rohde-schwarz.com/pws/dl_downloads/dl_application/application_notes/7mh89/7MH89_0E.pdf
- DOCSIS 3.1: Cable Tackles the Gigabit Challenge, SCTE white paper,
http://www.scte.org/SCTEDocs/WhitePapers/DOCSIS_3.1_Initiative_WhitePaper.pdf
- The Volpe Firm Website!!!